

Grizzly *Industrial, Inc.*®

MEAT-CUTTING BANDSAW MODEL G0560 INSTRUCTION MANUAL



COPYRIGHT © DECEMBER, 2003 BY GRIZZLY INDUSTRIAL, INC.
**WARNING: NO PORTION OF THIS MANUAL MAY BE REPRODUCED IN ANY SHAPE
OR FORM WITHOUT THE WRITTEN APPROVAL OF GRIZZLY INDUSTRIAL, INC.**
#5906 PRINTED IN TAIWAN

WARNING

Some dust created by power sanding, sawing, grinding, drilling, and other construction activities contains chemicals known to the State of California to cause cancer, birth defects or other reproductive harm. Some examples of these chemicals are:

- Lead from lead-based paints.
- Crystalline silica from bricks, cement, and other masonry products.
- Arsenic and chromium from chemically treated lumber.

Your risk from these exposures varies, depending on how often you do this type of work. To reduce your exposure to these chemicals: work in a well ventilated area, and work with approved safety equipment, such as those dust masks that are specially designed to filter out microscopic particles.

Table of Contents

SECTION 1: SAFETY	2
Safety Instructions for Power Tools	2
Additional Safety Instructions for Meat Saws	4
SECTION 2: GENERAL INFORMATION	5
SECTION 3: CIRCUIT REQUIREMENTS	6
Amperage Draw	6
Circuit Breaker	6
Plug-Type	6
Circuit Capacity	7
Grounding.....	7
Rewiring To 220V.....	7
Extension Cords.....	7
SECTION 4: MACHINE FEATURES	8
SECTION 5: SET UP	9
Unpacking	9
Inventory.....	9
Hardware Recognition Chart	11
Site Considerations	12
Clean Up	12
Stand	13
Switch & Cord	14
Wiring	15
Motor	15
Bandsaw Unit	16
V-Belt	16
Blade & Table Guards	17
Stand Covers	17
Table	18
Fence	20
Meat Grinder	21
SECTION 6: OPERATIONS	22
Blade Guard	22
Blade Guides	23
Blade Tension	23
Blade Tracking	24
Changing Blades	24
Support Bearing	25
Test Run.....	25
Cutting Meat.....	26
Cutting Bone	27
Grinding Meat.....	27
SECTION 7: CLEANING/SANITIZING	28
Cleaning the Saw	28
Proper Sanitation	29
SECTION 8: MAINTENANCE	30
SECTION 7: REFERENCE INFO	31
G0560 Data Sheet	32
G0560 Wiring Diagram.....	33
G0560 Parts Breakdown & Parts Lists	34
Warranty & Returns	38

SECTION 1: SAFETY

WARNING

For Your Own Safety, Read Instruction Manual Before Operating this Equipment

The purpose of safety symbols is to attract your attention to possible hazardous conditions. This manual uses a series of symbols and signal words which are intended to convey the level of importance of the safety messages. The progression of symbols is described below. Remember that safety messages by themselves do not eliminate danger and are not a substitute for proper accident prevention measures.

 **DANGER** Indicates an imminently hazardous situation which, if not avoided, **WILL** result in death or serious injury.

 **WARNING** Indicates a potentially hazardous situation which, if not avoided, **COULD** result in death or serious injury.

 **CAUTION** Indicates a potentially hazardous situation which, if not avoided, **MAY** result in minor or moderate injury. It may also be used to alert against unsafe practices.

NOTICE This symbol is used to alert the user to useful information about proper operation of the equipment.

WARNING

Safety Instructions for Power Tools

- 1. KEEP GUARDS IN PLACE** and in working order.
- 2. REMOVE ADJUSTING KEYS AND WRENCHES.** Form a habit of checking to see that keys and adjusting wrenches are removed from tool before turning on.
- 3. KEEP WORK AREA CLEAN.** Cluttered areas and benches invite accidents.
- 4. DO NOT USE IN DANGEROUS ENVIRONMENT.** DO NOT use power tools in damp or wet locations, or where any flammable or noxious fumes may exist. Keep work area well lighted.
- 5. KEEP CHILDREN AND VISITORS AWAY.** All children and visitors should be kept at a safe distance from work area.
- 6. MAKE WORKSHOP CHILD PROOF** with padlocks, master switches, or by removing starter keys.
- 7. DO NOT FORCE TOOL.** It will do the job better and safer at the rate for which it was designed.
- 8. USE RIGHT TOOL.** DO NOT force tool or attachment to do a job for which it was not designed.

WARNING

Safety Instructions for Power Tools

9. **USE PROPER EXTENSION CORD.** Make sure your extension cord is in good condition. Conductor size should be in accordance with the chart below. The amperage rating should be listed on the motor or tool nameplate. An undersized cord will cause a drop in line voltage resulting in loss of power and overheating. Your extension cord must also contain a ground wire and plug pin. Always repair or replace extension cords if they become damaged.

Minimum Gauge for Extension Cords

AMP RATING	LENGTH		
	25ft	50ft	100ft
0-6	16	16	16
7-10	16	16	14
11-12	16	16	14
13-16	14	12	12
17-20	12	12	10
21-30	10	10	No

10. **WEAR PROPER APPAREL.** DO NOT wear loose clothing, gloves, neckties, rings, bracelets, or other jewelry which may get caught in moving parts. Non-slip footwear is recommended. Wear protective hair covering to contain long hair.
11. **ALWAYS USE SAFETY GLASSES.** Also use face or dust mask if cutting operation is dusty. Everyday eyeglasses only have impact resistant lenses, they are NOT safety glasses.
12. **SECURE WORK.** Use clamps or a vise to hold work when practical. It is safer than using your hand and frees both hands to operate tool.
13. **DO NOT OVERREACH.** Keep proper footing and balance at all times.
14. **MAINTAIN TOOLS WITH CARE.** Keep tools sharp and clean for best and safest performance. Follow instructions for lubricating and changing accessories.

15. **USE RECOMMENDED ACCESSORIES.** Consult the instruction manual for recommended accessories. The use of improper accessories may cause risk of injury.

16. **REDUCE THE RISK OF UNINTENTIONAL STARTING.** On machines with magnetic contact starting switches there is a risk of starting if the machine is bumped or jarred. Always disconnect from power source before adjusting or servicing. Make sure switch is in OFF position before reconnecting.

17. **MANY WOODWORKING TOOLS CAN “KICKBACK” THE WORKPIECE** toward the operator if not handled properly. Know what conditions can create “kickback” and know how to avoid them. Read the manual accompanying the machine thoroughly.

18. **CHECK DAMAGED PARTS.** Before further use of the tool, a guard or other part that is damaged should be carefully checked to determine that it will operate properly and perform its intended function. Check for alignment of moving parts, binding of moving parts, breakage of parts, mounting, and any other conditions that may affect its operation. A guard or other part that is damaged should be properly repaired or replaced.

19. **NEVER LEAVE TOOL RUNNING UNATTENDED. TURN POWER OFF.** DO NOT leave tool until it comes to a complete stop.

20. **NEVER OPERATE A MACHINE WHEN TIRED, OR UNDER THE INFLUENCE OF DRUGS OR ALCOHOL.** Full mental alertness is required at all times when running a machine.

21. **NEVER ALLOW UNSUPERVISED OR UNTRAINED PERSONNEL TO OPERATE THE MACHINE.** Make sure any instructions you give in regards to the operation of the machine are approved, correct, safe, and clearly understood.

WARNING

Additional Safety Instructions for Meat Saws

- 1. DO NOT OPERATE WITH DULL OR BADLY WORN BLADES.** Dull blades require more effort to use and are difficult to control. Inspect blades before each use.
- 2. NEVER POSITION FINGERS OR THUMBS IN LINE WITH THE CUT.** Serious personal injury could occur.
- 3. DO NOT OPERATE THIS SAW WITHOUT WHEEL, PULLEY, AND BLADE GUARDS IN PLACE.**
- 4. WHEN REPLACING BLADES,** make sure teeth face down toward the table. The force of the cut is always down towards the table. Make sure the blade is properly tensioned.
- 5. CUTS SHOULD ALWAYS BE FULLY SUPPORTED** by the table or some type of support fixture.
- 6. DO NOT BACK MEAT AWAY** from the blade while the saw is running. Plan your cuts so you always cut through the meat. If you need to back the meat out, turn the bandsaw off and wait for the blade to come to a complete stop. Do not twist or put excessive stress on the blade while backing meat away.
- 7. BLADE SHOULD BE RUNNING AT FULL SPEED** before beginning a cut.
- 8. ALWAYS FEED MATERIAL EVENLY AND SMOOTHLY.** DO NOT force or twist blade while cutting, especially when sawing through bone.
- 9. DO NOT MANUALLY STOP OR SLOW BLADE** after turning off the saw. Allow it to come to a complete stop before you leave it unattended.
- 10. ALL INSPECTIONS, ADJUSTMENTS, AND MAINTENANCE ARE TO BE DONE WITH THE POWER OFF** and the plug pulled from the outlet. Wait for all moving parts to come to a complete stop.
- 11. HABITS—GOOD AND BAD—ARE HARD TO BREAK.** Develop good habits in your shop and safety will become second-nature to you.
- 12. IF AT ANY TIME YOU ARE EXPERIENCING DIFFICULTIES PERFORMING THE INTENDED OPERATION, STOP USING THE MACHINE!** Then contact our service department or ask a qualified expert how the operation should be performed.
- 13. ALWAYS SANITIZE AND CLEAN ALL EXPOSED PARTS OF SAW THOROUGHLY AFTER CUTTING MEAT.**
- 14. IF YOU ARE NOT FAMILIAR WITH SAFE MEAT HANDLING TECHNIQUES,** then contact your local Board of Health or the USDA for proper sanitary practices.

WARNING

Bacteria from raw meat has been frequently linked to illness and even death! Describing proper meat handling techniques outside of cleaning the bandsaw is beyond the scope of this manual. If you are unclear about sanitary meat handling practices, contact your local Board of Health or the USDA to research the proper methods of meat handling.

CAUTION

No list of safety guidelines can be complete. Every shop environment is different. Always consider safety first, as it applies to your individual working conditions. Use this and other machinery with caution and respect. Failure to do so could result in serious personal injury, damage to equipment or poor work results.

SECTION 2: GENERAL INFORMATION

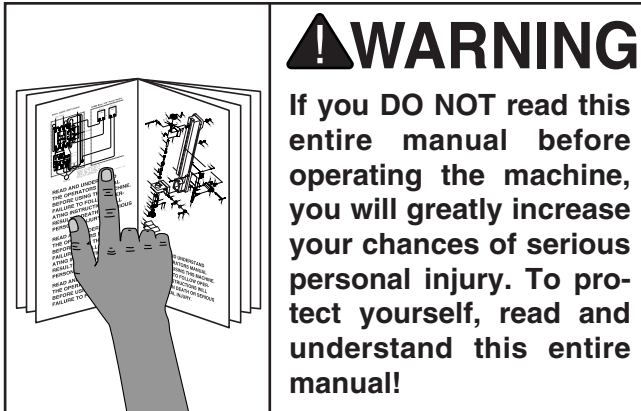

Commentary

Grizzly Industrial, Inc. is proud to offer the Model G0560 Meat-Cutting Bandsaw. This machine is part of Grizzly's growing family of fine machinery. When used according to the guidelines stated in this manual, you can expect years of trouble-free, enjoyable operation.

The Model G0560 is intended for home or professional butchers and is capable of cutting through meat and bones. The stainless steel table and easy disassembly of parts allow for proper cleaning and sanitation.

We are also pleased to provide this manual with the Model G0560. It was written to guide you through assembly, review safety considerations, and cover general operating procedures. It represents our latest effort to produce the best documentation possible.

If you have any comments or criticisms that you feel we should address in our next printing, please write to us at:

Grizzly Industrial, Inc.
% Technical Documentation
P.O. Box 2069
Bellingham, WA 98227

Most important, we stand behind our machines. We have excellent regional service departments at your disposal should the need arise.

If you have any service questions or parts requests, please call or write to us at the location listed below.

Grizzly Industrial, Inc
1203 Lycoming Mall Circle
Muncy, PA 17756
Phone:(570) 546-9663
Fax:(800) 438-5901
E-Mail: techsupport@grizzly.com
Web Site: <http://www.grizzly.com>

The specifications, drawings, and photographs illustrated in this manual represent the Model G0560 as supplied when the manual was prepared. However, owing to Grizzly's policy of continuous improvement, changes may be made at any time with no obligation on the part of Grizzly. For your convenience, we always keep current Grizzly manuals available on our website at www.grizzly.com. Any updates to your machine will be reflected in these manuals as soon as they are complete.



SECTION 3: CIRCUIT REQUIREMENTS

Amperage Draw

The Model G0560 features a 110/220V $\frac{3}{4}$ HP motor that is prewired at 110V.

Amperage Draw

110V (prewired)	12 Amps
220V	6 Amps



Circuit Breaker

Use the following guidelines when choosing a circuit breaker (circuit breakers rated any higher are not adequate to protect the circuit):

Circuit Breaker

110V (prewired)	20 Amp, 1 Pole
220V	10 Amp, 2 Pole



Plug-Type

The cord set enclosed is equipped with a NEMA 5-15 plug (**Figure 1a**).

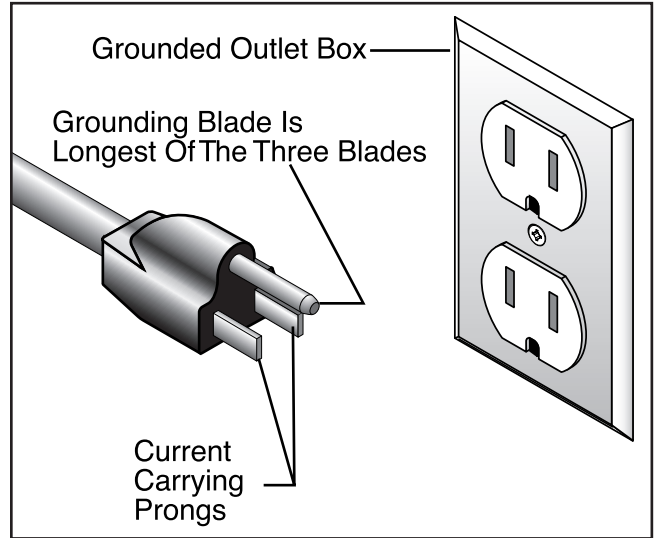

Figure 1a. NEMA 5-15 plug and receptacle.

If the bandsaw is rewired to operate on a 220V power source, the plug must be replaced with a NEMA 6-15 plug (**Figure 1b**).

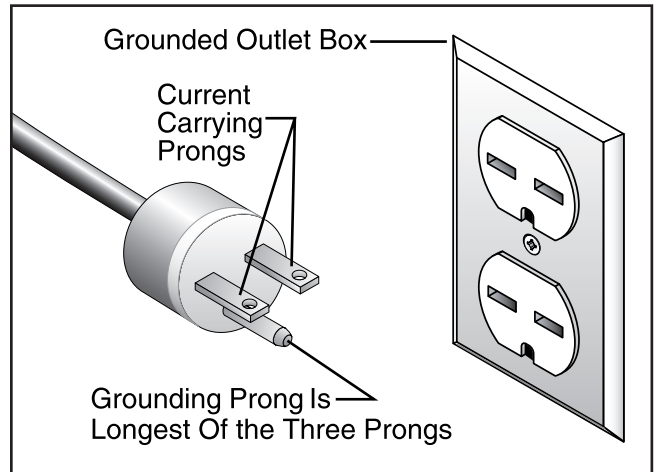

Figure 1b. NEMA 6-15 plug and receptacle.



Circuit Capacity

Always check to see if the wires in your circuit are capable of handling the amperage draw from your machine, as well as any other machines that could be operating on the same circuit. If you are unsure, consult a qualified electrician.

If the circuit breaker trips or the fuse blows regularly, your machine may be operating on a circuit that is close to its amperage draw capacity. However, if an unusual amperage draw does not exist and a power failure still occurs, contact a qualified electrician.



Grounding

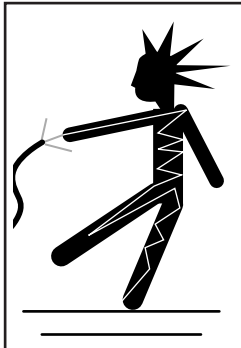

⚠ WARNING
Electrocution or a fire can result if the machine is not grounded correctly. Make sure all electrical circuits are grounded. **DO NOT** use the machine if it is not grounded.

NOTICE

The wire on the power cord with green or green and yellow striped insulation is the grounding conductor.

In the event of an electrical short, grounding reduces the risk of electric shock by providing a path of least resistance to disperse electric current. This tool is equipped with a power cord that has an equipment-grounding prong. The outlet must be properly installed and grounded in accordance with all local codes and ordinances.



Rewiring To 220V

The Model G0560 can be rewired to operate on a 220V power source. The motor must be rewired according to the wiring diagram on the motor label. The wiring configuration can also be found on the inside of the motor wire cover, as well as on **page 33**.

This procedure takes moderate electrical skill and the rewiring job should be inspected by a licensed electrician before turning the machine *ON*.



Extension Cords

If you find it necessary to use an extension cord with this machine:

- Only use a cord that is rated for standard service (Grade S).
- Only use a cord that contains a grounding prong.
- Use at least a 16 gauge cord if the cord is 50 feet long or less.
- Use at least a 14 gauge cord if the cord is between 50-100 feet.
- Always repair or replace cords when they become worn or damaged.

We **DO NOT** recommend using an extension cord if you are operating your bandsaw on a 220V power source.



SECTION 4: MACHINE FEATURES

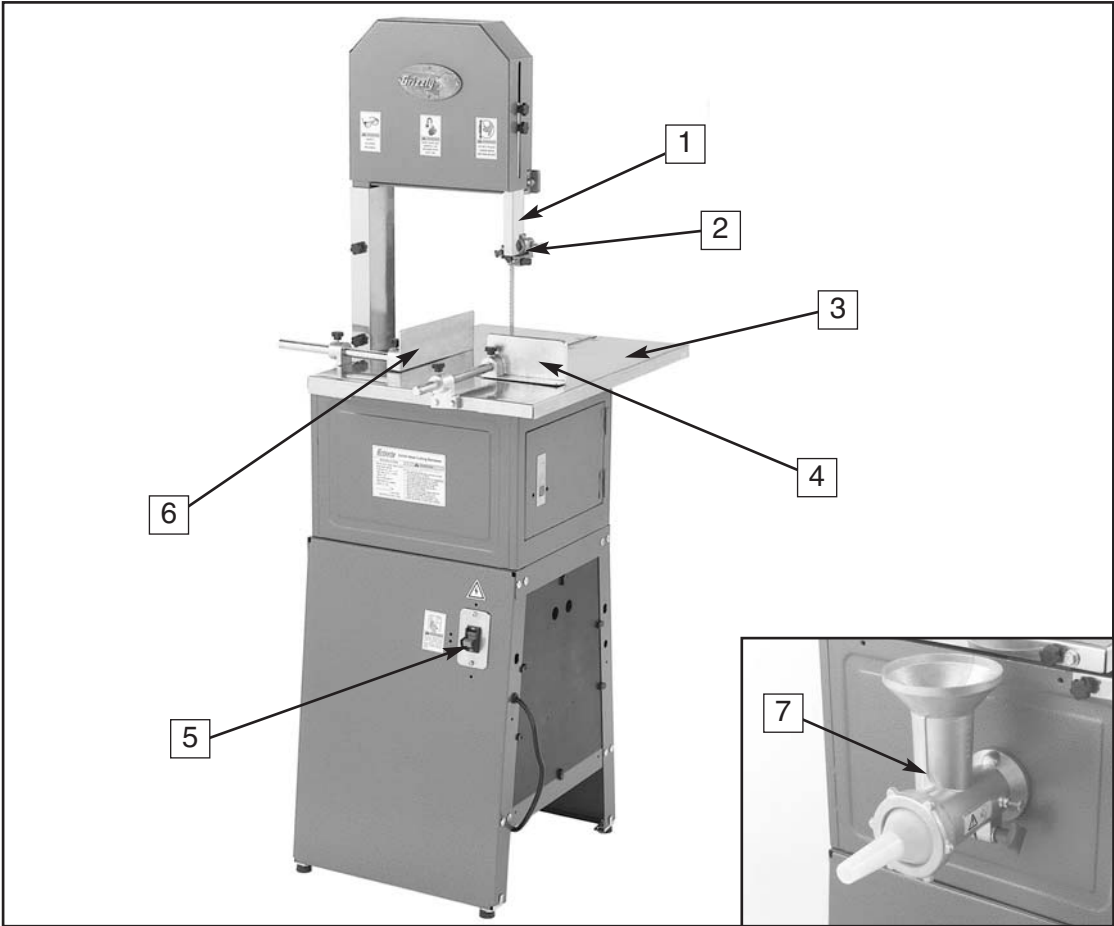
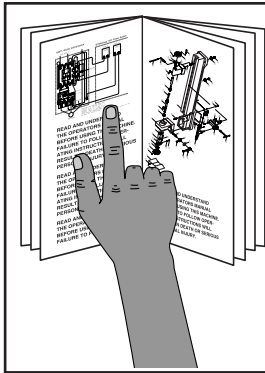

Figure 2. Main view of machine features.

- 1. Adjustable Blade Guard
- 2. Blade Guide
- 3. Sliding Table
- 4. Small Cutting Fence
- 5. ON/OFF Switch
- 6. Large Cutting Fence
- 7. Meat Grinder/Sausage Stuffer



SECTION 5: SET UP



! WARNING
 This machine presents serious injury hazards to untrained users. Read through this entire manual to become familiar with the controls and operations **BEFORE** starting the machine!

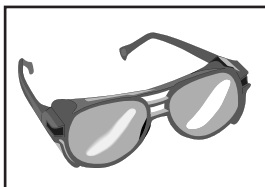

! WARNING
 Wear safety glasses during the entire set up process!

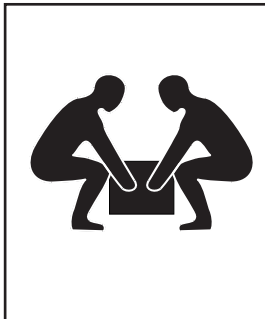

! WARNING
 The Model G0560 is a heavy machine (127 lbs. shipping weight). **DO NOT** over-exert yourself while unpacking or moving your machine—get assistance.

Unpacking

This machine left our warehouse in a carefully packed crate or box. If you discover the machine is damaged after you have signed for delivery, *please immediately call Customer Service at (570) 546-9663 for advice.*

Save the containers and all packing materials for possible inspection by the carrier or its agent. *Otherwise, filing a freight claim can be difficult.*

When you are completely satisfied with the condition of the shipment, you should inventory the equipment.



Inventory

After all the parts have been removed from the carton, you should have:

Base Unit (Figure 3)

- A. Model G0560 Bandsaw Base Unit.....1



Figure 3. Bandsaw base unit.

B. Stand Hardware Bag

- Knob Screw M6-1 x 12.....17
- Special Hex Bolt M10-1.5 x 16.....3
- Hex Bolt M8-1.25 x 204
- Carriage Bolt M8-1.25 x 1622
- Hex Nut M8-1.2530
- Flat Washer 8mm34
- Hex Bolt M6-1 x 20.....4
- Hex Bolt M6-1 x 12.....4
- Flat Washer 6mm8
- Tap Screw #6 x 3/8"12
- Catch Tab12

Stand Pieces (Figure 4)

C.	Front Panel	1
D.	Rear Panel	1
E.	Top Panel.....	1
F.	Top Panel “S” Brace	1
G.	Motor Mount Plate	1
H.	Plastic Side Panel	2
I.	Lower Brace.....	2
J.	Foot Hardware	
	—Rubber Feet	4
	—Feet Mount Bracket	4

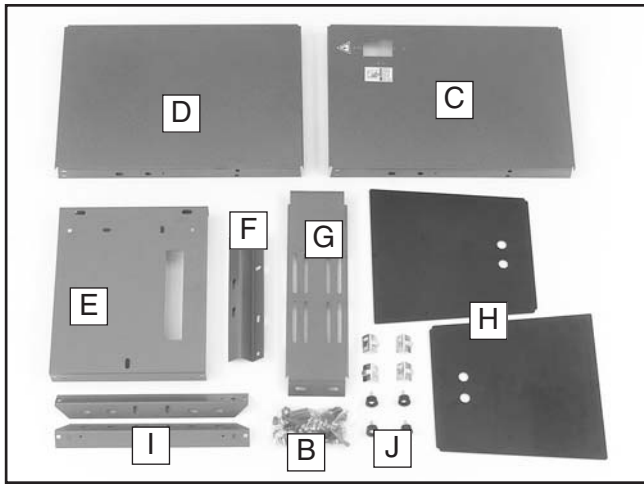

Figure 4. Stand pieces.

Table, Fence and Grinder Pieces (Figure 5)

L.	Table	1
M.	Slide Rail	2
N.	Large Fence.....	1
O.	Small Fence.....	1
P.	Fence Rod	2
Q.	Fence Bracket	2
R.	Table Force Plate	1
S.	Grinder Assembly	1
T.	Plastic Pusher	1
U.	Sausage Stuffer.....	1
V.	Blade Protection Plate	1
W.	Blade Guard.....	1
X.	Table Guard.....	1

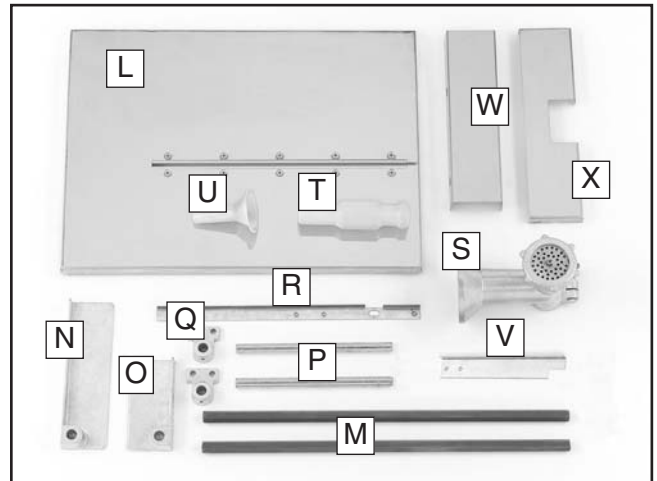

Figure 5. Table, fence and grinder pieces.

Motor, drive belt and switch pieces (Figure 6)

Y.	Motor w/ Motor Pulley	1
Z.	Switch Backside Cover	1
AA.	Power Switch	1
BB.	Power Cord	1
CC.	V-Belt A-53	1

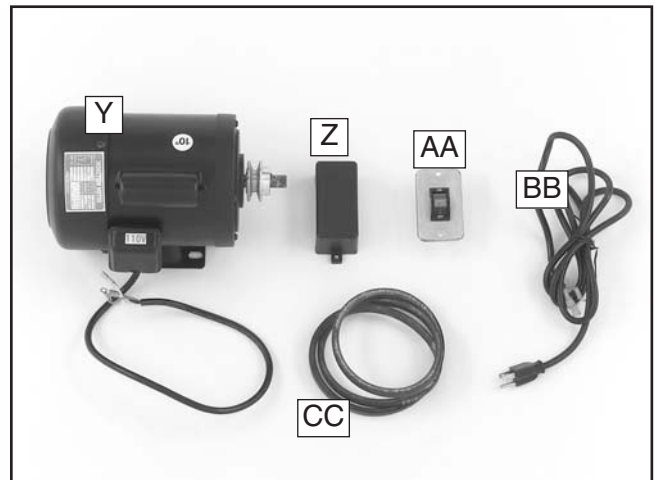

Figure 6. Motor, drive belt, and switch pieces.

In the event that any nonproprietary parts are missing (e.g. a nut or a washer), we would be glad to replace them, or, for the sake of expediency, replacements can be obtained at your local hardware store.



Hardware Recognition Chart

USE THIS CHART TO MATCH UP
HARDWARE DURING THE ASSEMBLY
PROCESS!

MEASURE BOLT DIAMETER BY PLACING INSIDE CIRCLE

- #10
- 1/4"
- 5/16"
- 3/8"
- 7/16"
- 1/2"

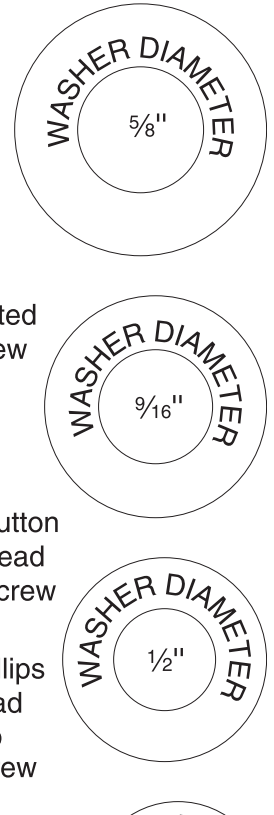
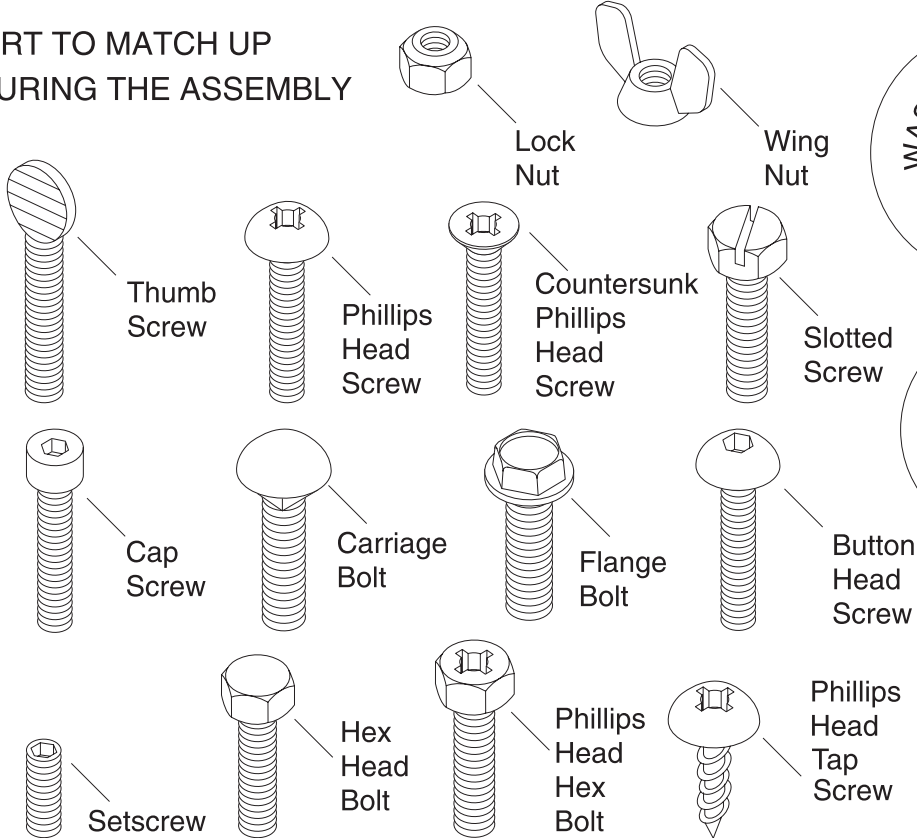

- 5/8"
- 4mm

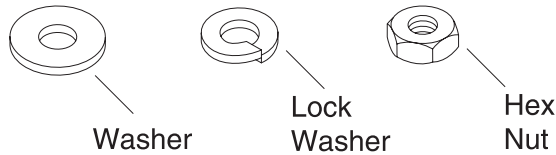

WASHERS ARE MEASURED BY THE INSIDE DIAMETER

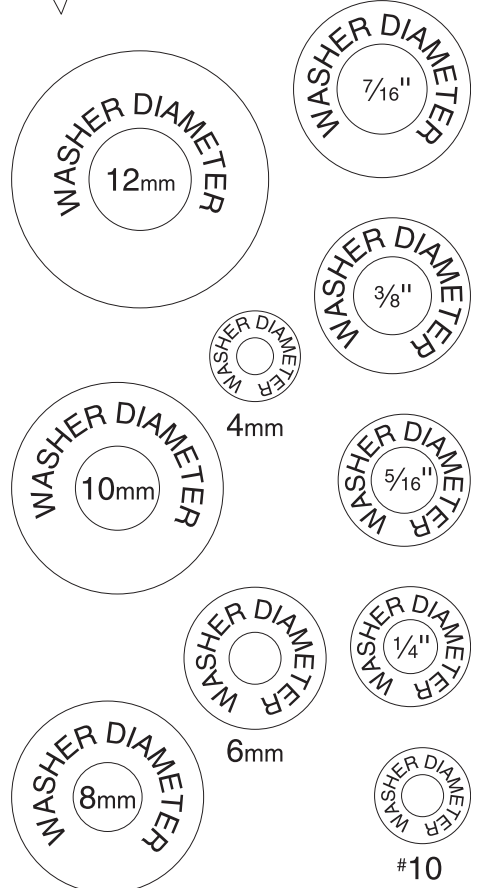

- 6mm
- 8mm
- 10mm
- 12mm
- 16mm

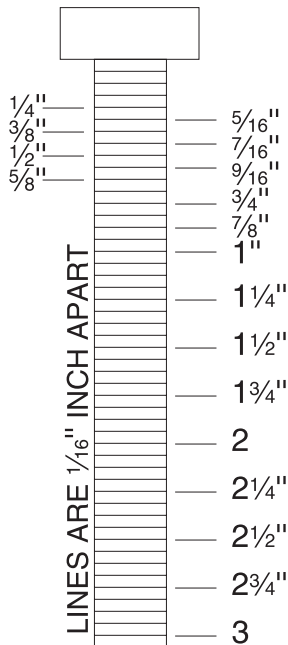
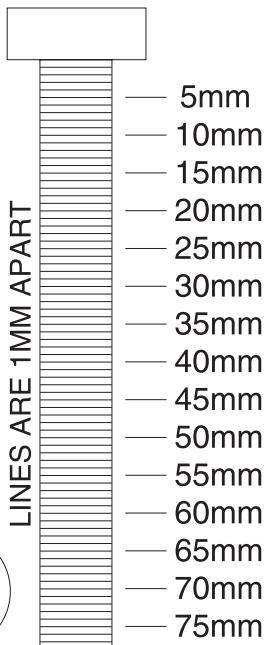

Site Considerations

	<p>⚠ CAUTION</p> <p>Unsupervised children and visitors could cause serious personal injury to themselves with this machine. Choose a site for placement in your shop where you can safely lock visitors and children away when you are not with them.</p>
---	---

Floor Load

The Model G0560 weighs 127 lbs. and has a base footprint of 16" x 18".

Working Clearances

Consider existing and anticipated needs, size of material to be processed, and space for auxiliary stands, work tables or other machinery when establishing a location for your bandsaw.



Clean Up

The table and guard pieces come with a protective coating. Peel this off before cleaning these pieces. Clean and sanitize all parts of the saw that will be in contact with meat or any other food items. The smaller items and table will fit in most dishwashers. This is probably the easiest method of cleaning and sanitizing these parts. For the larger parts of the saw, if a dishwasher is not available, clean with a sanitizing agent. See **Section 5: Sanitation** for details on sanitizing. Get in the habit of cleaning your saw thoroughly to avoid contamination and illnesses.

<p>⚠ WARNING</p> <p>When cleaning with sanitizers, always follow the recommendations on the manufacturer's label, and make sure that the product will do the job for which you intend. Never use a product that will make your meat unsafe for human consumption. Failure to follow this warning may lead to sickness or death!</p>



Stand

Components and Hardware Needed:	Qty
Rubber Feet	4
Feet Bracket	4
Hex Bolt M6-1 x 20	4
Stand Side	2
Stand Side Brace	2
Stand Top	1
Top Panel "S" Brace	1
Motor Mounting Bracket	1
Carriage Bolt M8-1.25 x 16	16
Hex Nut M8-1.25	20
Flat Washer 8mm	20

Tools Needed:

10mm Wrench or Socket.....	2
----------------------------	---

To assemble the stand:

All stand pieces except the rubber feet should be assembled with the M8-1.25 x 16 carriage bolts, M8 hex nuts, and 8mm washers.

1. Attach the stand sides to the stand top as shown in **Figure 7**. Make sure the side of the stand with the switch cutout is on the same side as the V-belt cutout on the top piece. This will ensure that the switch is in front of the bandsaw. Do not completely tighten the carriage bolt nuts at this time.

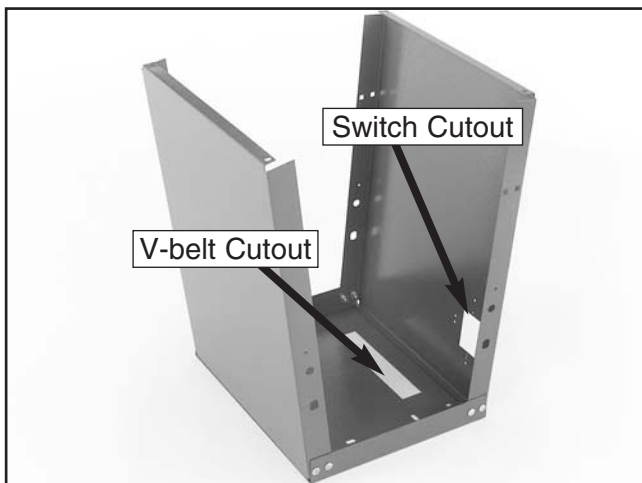

Figure 7. Stand sides attached to stand top.

2. Place the (4) feet brackets on the stand corners where the rubber feet will be installed.
3. Insert the (4) M6-1 x 20 hex bolts into the rubber feet and attach the feet to the stand corners as shown in **Figure 8**.

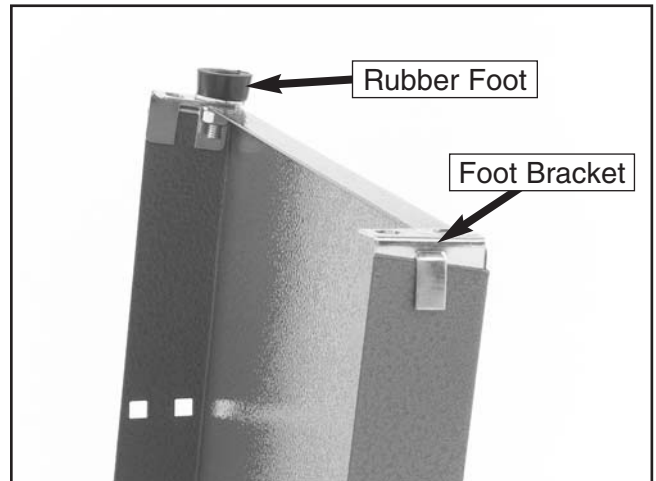

Figure 8. Rubber foot and foot brackets.

4. Attach the side braces to the stand sides as shown in **Figure 9**.

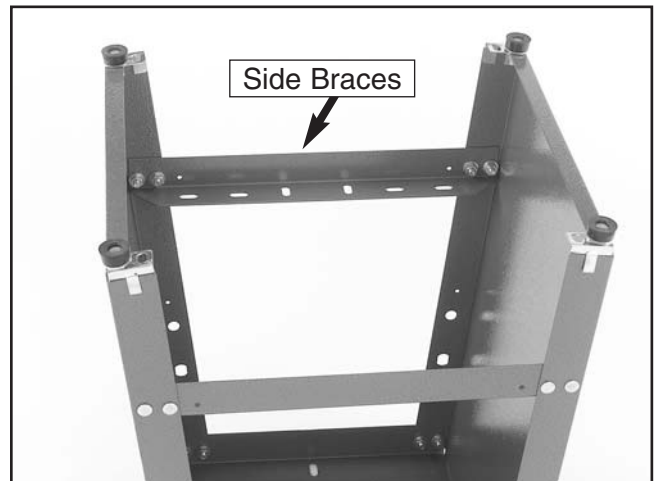

Figure 9. Stand braces attached to stand sides.

- Attach the motor mounting plate to the top panel "S" brace with (2) $\frac{5}{16}$ "-18 x $\frac{1}{2}$ " carriage bolt, $\frac{5}{16}$ " washers and $\frac{5}{16}$ "-18 hex nuts (**Figure 10**).

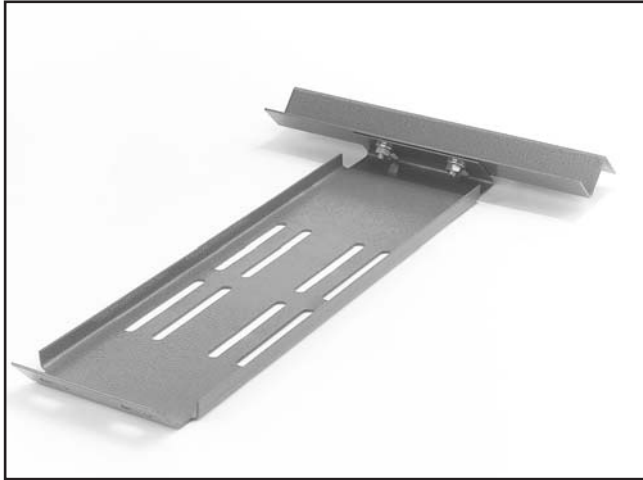

Figure 10. Motor mounting bracket attached to the top panel "S" brace.

- Attach the motor mounting plate with the top panel "S" brace to the inside of the stand as shown in **Figure 11**.

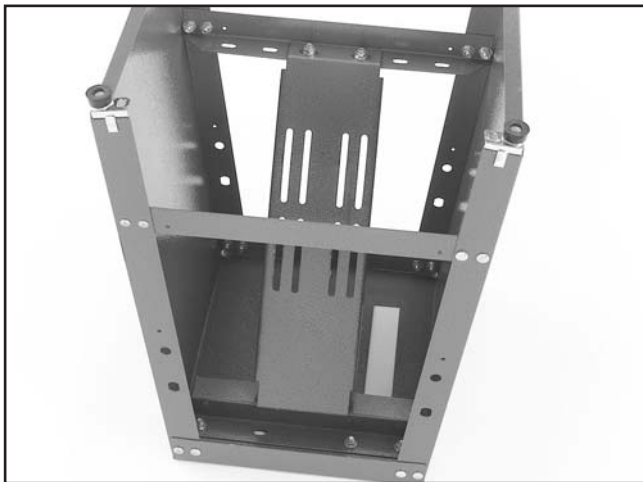

Figure 11. Top brace to stand top.

- Turn the stand over on its feet to square out the sides and tighten the remaining loose nuts.



Switch & Cord

Components and Hardware Needed:	Qty
Switch	1
Switch Cover	1
Power Cord	1

Tools Needed:

Phillips Head Screwdriver	1
---------------------------------	---

To install the switch and power cord:

Mount the switch on the stand side with the (2) 10-24 x 1" Phillips screws, 10-24 nuts, and star washers.

- Place the strain relief into the hole on the stand side. Thread the plastic nut onto the back side of the strain relief.
- Make sure the plastic setscrew is withdrawn enough to allow the cord to come through the strain relief, then push the end of the cord with the wires through the strain relief.
- Allow enough room for the red and black wires to reach the switch and the green wire to reach the ground (hole below the switch).
- Tighten the plastic setscrew to secure the cord in place. Mount the switch and cord to the stand side as shown in **Figure 12**.



Figure 12. Switch & cord installed on stand.



Motor

Components and Hardware Needed:	Qty
Motor	1
Hex Bolt M8-1.25 x 20.....	4
Hex Nut M 8-1.25	4
Flat Washer 8mm	8

Tools Needed:
Wrench or Socket 10mm.....1

To install the motor:

1. Place the motor on the mounting plate so the motor pulley is directly under the pulley slot in the top of the stand.
2. Fasten the motor onto the motor mount (as shown in **Figure 13**) with the hex bolts, hex nuts, lock washers and flat washers. The washers should be placed on both sides of the motor mount.

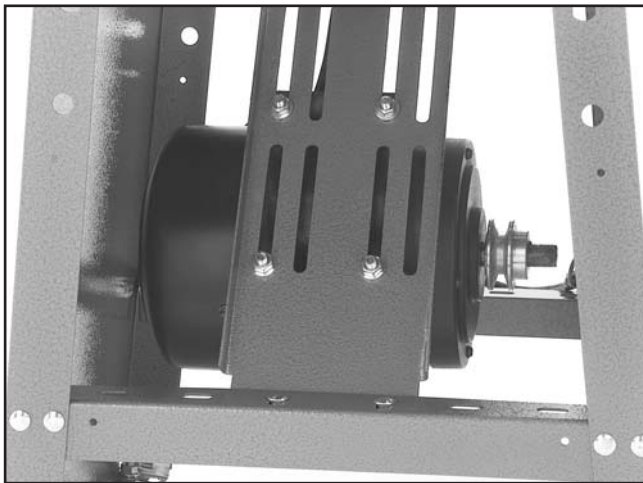

Figure 13. Motor mounted to motor mount.



Wiring

The diagram in **Figure 14** shows the proper wiring of the motor and the power cord. The ground wires mount underneath the switch with the 10-24 x 1/2" Phillips screw, nut and star washer. Do not pinch the wires while installing them. If they will not reach, carefully cut back the outer layer of the black cord. **Do not cut insulation on the smaller wires inside!**

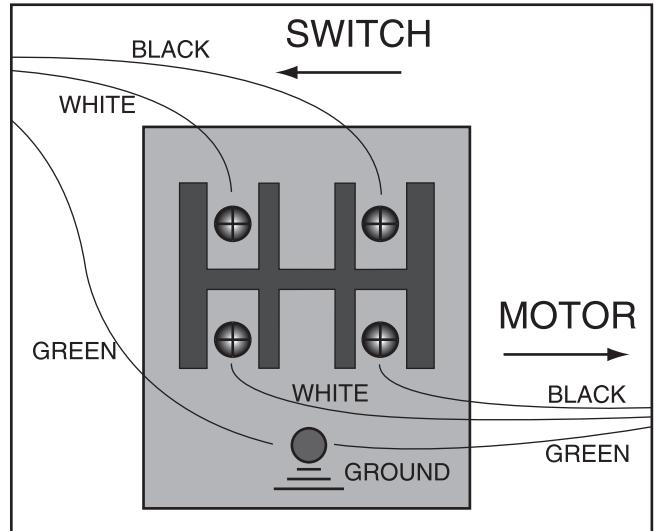



Figure 14. Wiring to switch plate.

After everything is wired correctly, take off the nuts that hold the switch over the mounting hole in the stand. Slide the rubber cover over the back of the switch so no metal contacts are exposed. Push the mounting screws through the holes on the ends of the cover and thread the nuts back on the screws. Tighten them securely, but not tight enough to ruin the rubber.



Bandsaw Unit

Components and Hardware Needed:	Qty
Bandsaw Base Unit.....	1
Special Hex Bolt M10-1.5 x 16	3

	<p>⚠ WARNING</p> <p>The Model G0529 weighs 127 lbs. Personal injury could occur if the machine is moved without additional assistance. Seek help when moving or lifting the machine.</p>
---	---

To install the bandsaw unit onto the stand:

1. Place the bandsaw base unit onto the stand as shown in **Figure 15**. Get help so you do not strain yourself.



Figure 15. Bandsaw unit on stand.

2. Line up the holes in the corner of the stand with the holes on the bottom of the bandsaw unit.
3. Fasten the stand to the bandsaw unit with the (3) M10-1.5 x 16 special hex bolt as shown in **Figure 16**.



Figure 16. Installing special hex bolt.



V-Belt

Before you put on the V-belt, make sure that the motor pulley and the upper pulley are reasonably aligned. To do this, loosen the setscrew on the motor pulley, adjust the motor pulley so it is in-line with the upper pulley, then tighten the setscrew.

To put on the V-belt:

1. Loosen the (4) motor mount bolts.
2. Raise the motor up and fit the V-belt in the pulley grooves, then let the motor down.
3. Place slight pressure on the motor to tension the belt and tighten the (4) motor mount bolts. Make sure that the motor does not twist and double check the pulley alignment. Adjust the positioning as needed.
4. Check for approximately 1/4" deflection. If the belt is not tensioned correctly, repeat **steps 1 and 3** until it is correct.



Stand Covers

Components and Hardware Needed:	Qty
Tap Screws #6 x $\frac{3}{8}$ "	12
Catch Tabs	12
Stand Covers.....	2

Tools Needed:

Phillips Head Screwdriver	1
---------------------------------	---

The stand covers need catch tabs installed in all the predrilled holes as shown in **Figure 17 & 18**.

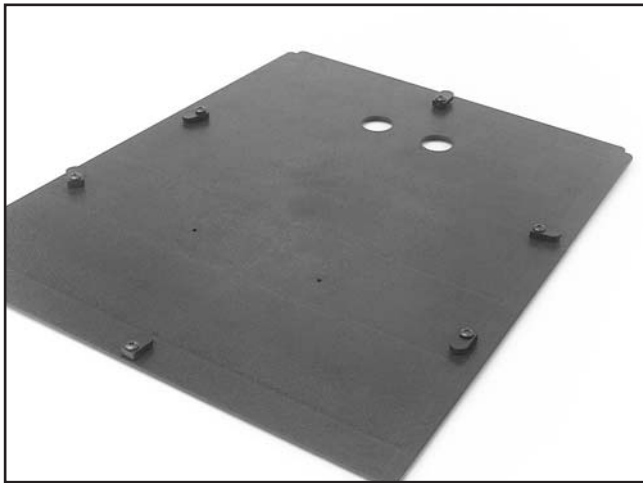

Figure 17. Stand covers with catch tabs.

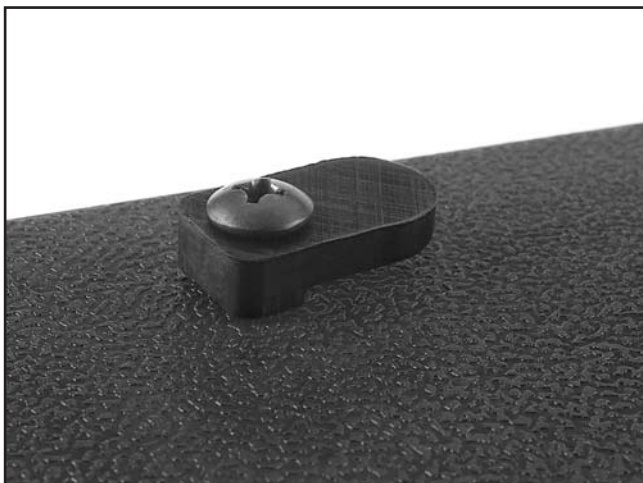

Figure 18. Catch tab in place on stand cover.

The stand covers fit inside the stand openings and attach by turning the catch tabs over the edges of the stand.



Blade & Table Guards

The blade and table guards prevent contaminants from falling into the saw.

Components and Hardware Needed:	Qty
Blade Guard	1
Table Guard	1
Knob Screw M6-1 x 12	6

To install the guards:

1. Place the table guard around the bandsaw throat on the top edge as shown in **Figure 19**.

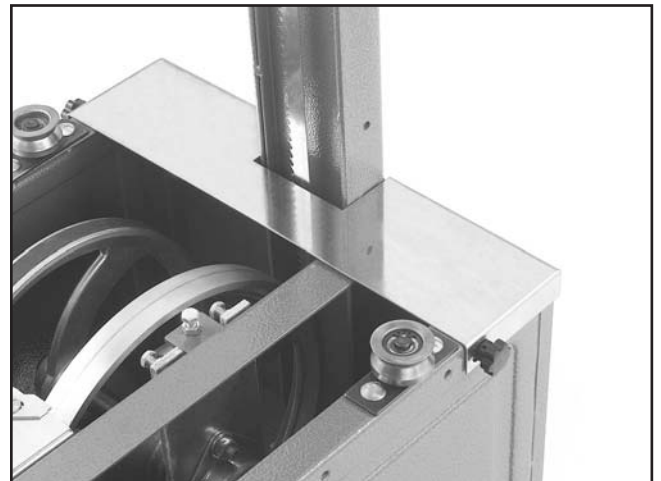

Figure 19. Table guard installed.

2. Secure the table guard in place with a knob screw on each side of the guard.
3. Place the blade guard around the side of the bandsaw covering the blade as shown in **Figure 20**.

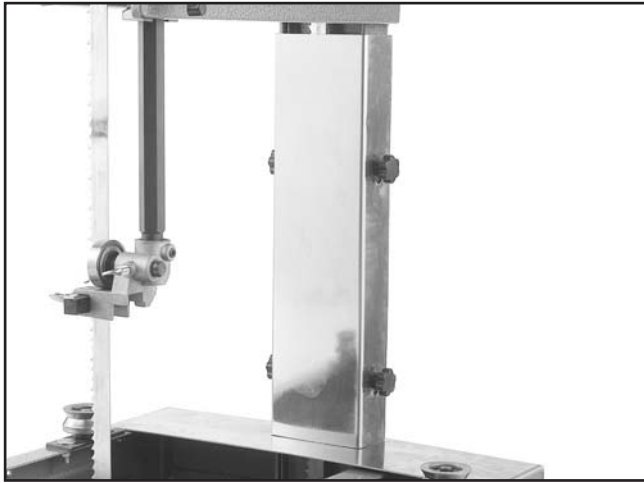

Figure 20. Blade guard installed.

4. Secure the blade guard in place with two knob screws on each side.



Table

The sliding table allows you to move the blade through the meat.

Components and Hardware Needed:	Qty
Sliding Table	1
Rail	2
Force Plate	1
Knob Screw M6-1 x 12	4
Hex Bolt M6-1 x 12	4
Flat Washer 6mm	4

To install the sliding table:

1. Secure one end of each rail to the underside of the sliding table as shown in **Figure 21**. Note—Secure the rail ends to the closed side of the sliding table.

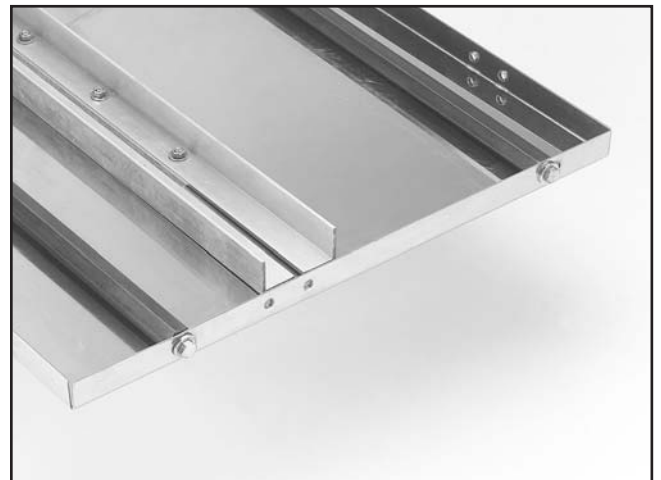

Figure 21. Installing rails on table.

2. Slide the bandsaw blade through the slot in the sliding table and place the table on the rollers. *Note—Be careful when placing the table on the saw. The other end of the rails are not secured to the table.*
3. Secure the force plate under the open edge of the table with the M6-1 x 12 knob screws as shown in **Figure 22**.

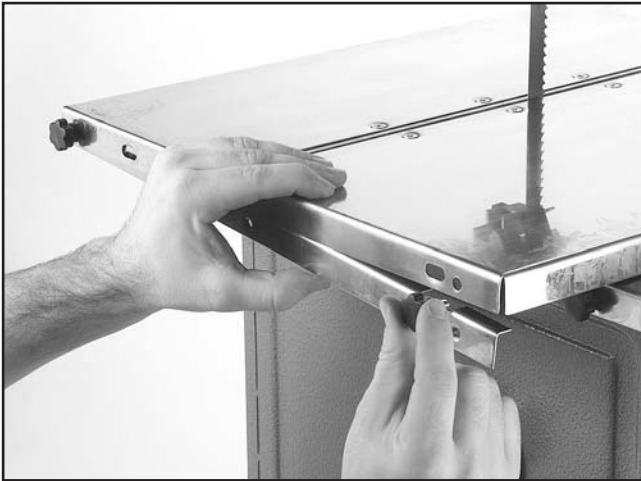

Figure 22. Installing force plate.

4. Secure the rails to the end of the table using the knob screws as shown in **Figure 23**.

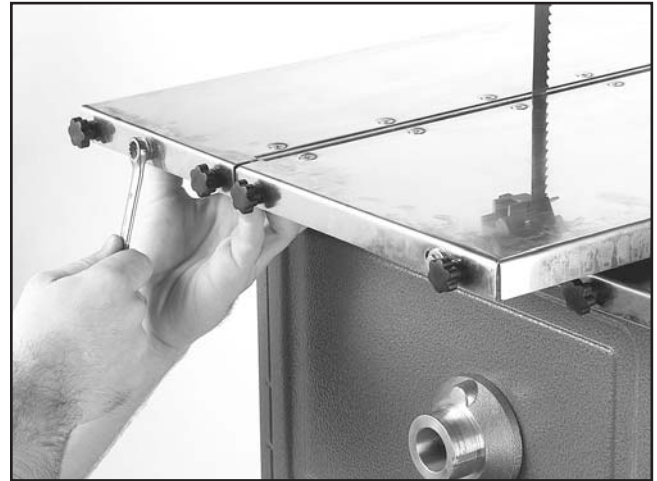

Figure 23. Securing rails in the sliding table.

5. Tighten the rails in place so that they slide in the roller groove.

Note—This table adjustment may take some trial and error. It is best to position the inside rail so the blade is centered in the slot, then squeeze the outer rail into the roller groove and tighten the knob screws. It is important that the rails are secure in the rollers and the blade does not make contact with the table.

6. Check to make sure the rails are in the roller grooves and that the table slides smoothly (**Figure 24**).



Figure 24. Checking table position.



Fence

The fences allow you to support the meat as you slide it through the blade while also controlling the thickness of cut.

Components and Hardware Needed:	Qty
Fence Support Brackets	2
Hex Bolts M6-1 x 20	4
Fence Shafts	2
Fences.....	2
Knob Screws M6-1 x 12	4
Flat Washer	4

Tools Needed:

Wrench 10/12mm	1
----------------------	---

To install the fence:

1. Use the M6-1 x 20 hex bolts to attach the fence brackets to the table as shown in **Figure 25**.



Figure 25. Fence supports to table.

2. Insert the fence shafts into the fences and secure them in place with the knob screws (**Figure 26**).

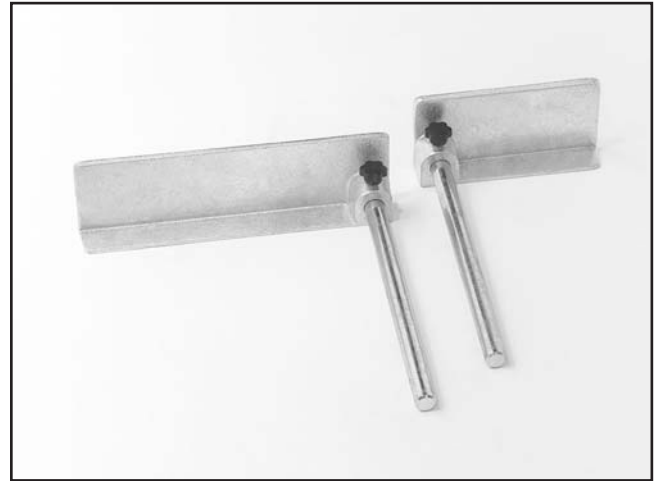

Figure 26. Fences assembled.

3. Slide the long fence into the bracket on the left and the short fence into the bracket in front (**Figure 27**).
4. Secure the fence assemblies in the brackets with knob screws.

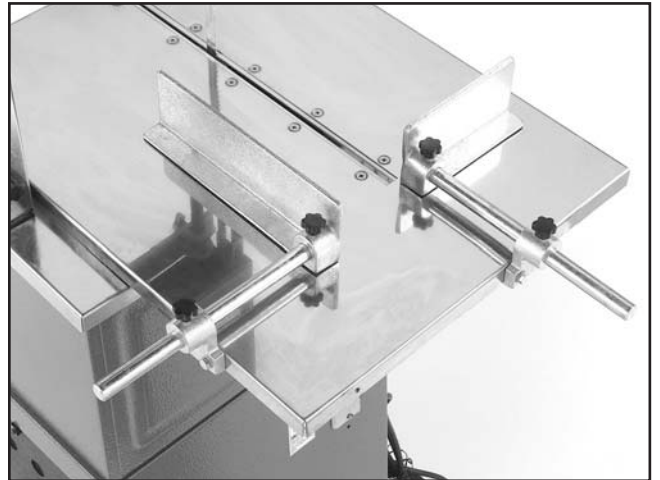

Figure 27. Fences installed on supports.



Meat Grinder

The Model G0560 comes with a meat grinder. Before assembling this for use, clean and sanitize its parts. See **Section 5: Sanitation** for details on sanitizing. **Figure 28** shows the meat grinder components.

⚠ CAUTION

The meat grinder should not be attached to the saw when not in use. Meat fat is required to lubricate the grinder components during operation. Grinder will be damaged if allowed to turn “dry”.



Figure 28. Meat grinder components.

To install the meat grinder:

1. **Disconnect the machine from the power source!**
2. Line up the fixed key on the meat grinder to the keyway on the housing shown in **Figure 29**.

⚠ CAUTION

The meat grinder should not be attached to the saw when not in use. The open chute and spinning auger easily invite an accident if not being attended to.

3. Slide the meat grinder all the way into the housing and tighten the split collar to secure the grinder in place.

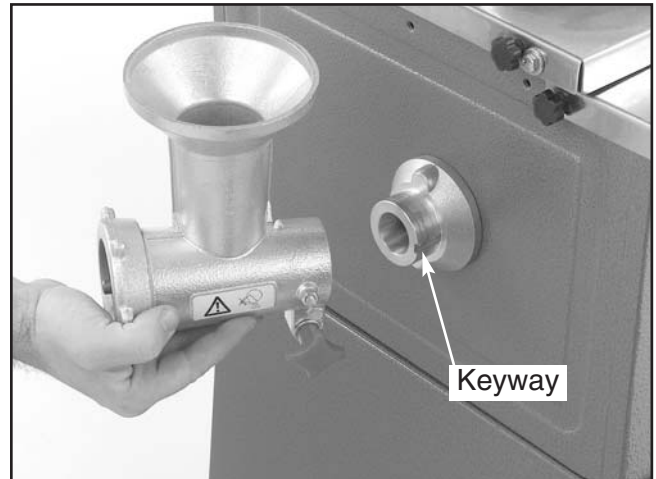

Figure 29. Keyway location.

The meat grinder comes with a sausage stuffer attachment.

To install the sausage stuffer:

1. Remove the collar from the end of the meat grinder housing.
2. Fit the collar over the sausage stuffer.
3. Place the collar back on the housing as shown in **Figure 30**, and thread it tight so it is secured to the housing.

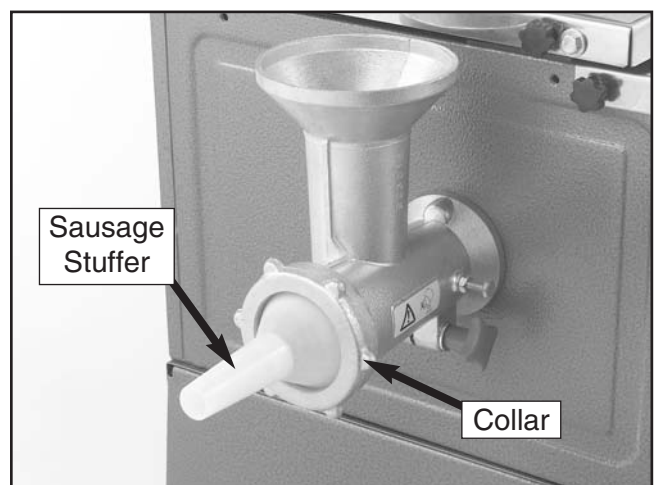

Figure 30. Sausage stuffer attachment.



SECTION 6: OPERATIONS

⚠️ WARNING

Damage to your eyes and ears could result from using this machine without proper protective gear. Always wear safety glasses and hearing protection when operating this machine.



The Model G0560 is operated by an ON/OFF paddle switch that is clearly labeled on the side of the stand.

This switch is locked out when the key is removed to protect against accidental operation (**Figure 31**).



Figure 31. Switch lock out.



Blade Guard

Figure 32 shows the blade guard controls. The blade guard protects the operator from accidental contact with the part of the blade that is not being used.

The star knob on the guide rail allows you to raise and lower the blade guard and blade guide assembly. Keep the blade guide assembly within an inch of the material you are cutting. This will provide adequate support for the blade where the pressure is greatest. **This adjustment is crucial for safe operation when cutting through bone!**

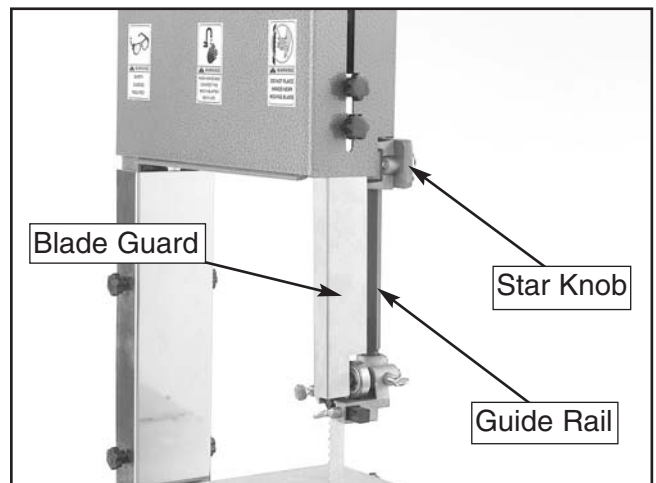

Figure 32. Blade guard.



Blade Guides

The upper blade guides shown in **Figure 33** support the blade from moving side-to-side while cutting. These should be adjusted to approximately 0.004" (about the thickness of a dollar bill) away from the blade and should be behind the gullet of the blade teeth.

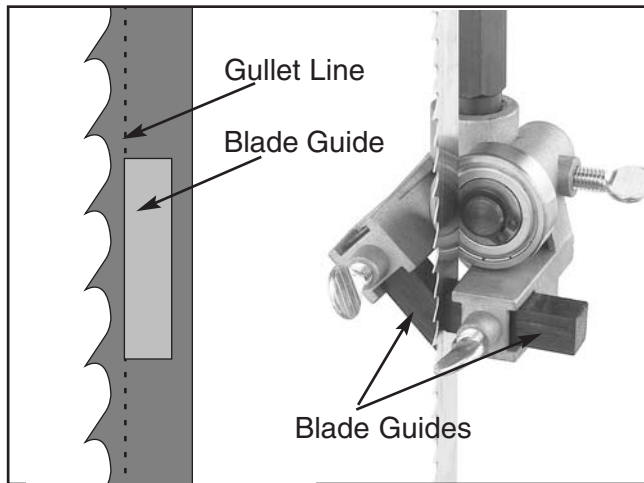

Figure 33. Upper blade guide.

The lower blade guides shown in **Figure 34** are underneath the table. These can be adjusted with a screwdriver and should be set in the same manner as the upper blade guides.

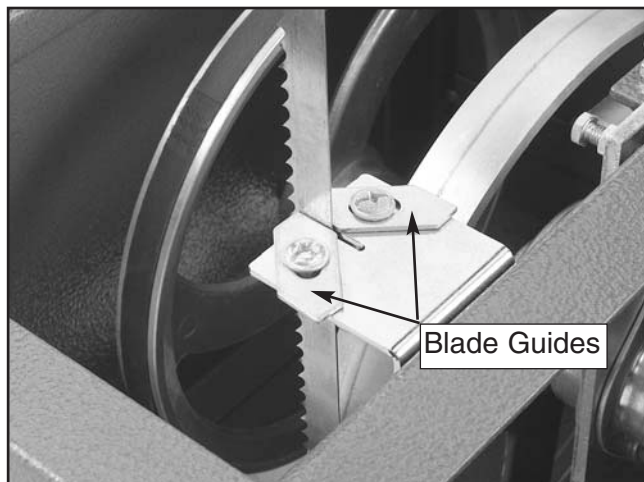

Figure 34. Lower blade guide.



Blade Tension

The bandsaw blade must be adequately tensioned so that it will cut straight and not fall off the wheel during operation.

To tension the bandsaw blade:

1. **Disconnect the machine from the power source!**
2. Remove the thumbscrew that secures the upper cover, then pull the upper cover off the bandsaw unit to expose the upper wheel.
3. Turn the tension bolt (shown in **Figure 35**) counterclockwise to decrease the tension and clockwise to increase the tension.

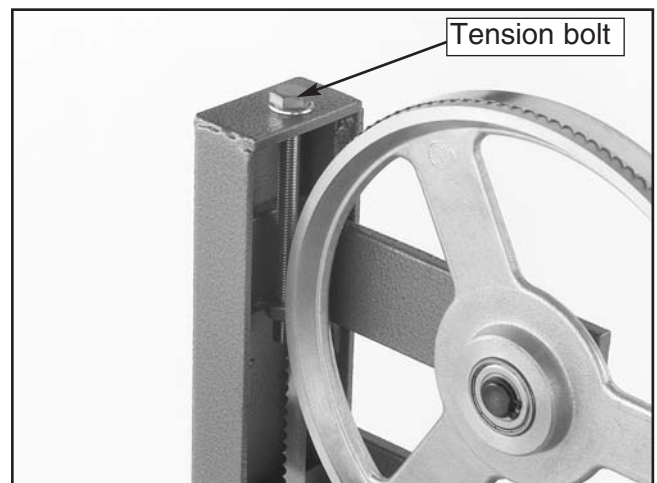

Figure 35. Blade tension bolt.

4. Tension the blade so that it deflects approximately 1/4" with moderate pressure from your finger.

A warning icon consisting of a large exclamation mark above a power cord with a two-prong electrical plug.	<p>⚠ WARNING Disconnect power to the machine when performing any adjustments or maintenance. Failure to do this may result in serious personal injury.</p>
--	---



Blade Tracking

The bandsaw blade must be properly tracked (or centered) on the wheels.

To track the blade:

1. **Disconnect the machine from the power source!**
2. Remove the upper wheel cover from the bandsaw.
3. The blade tracking controls are shown in **Figure 36**. Each setscrew moves that portion of the wheel in or out. For example, the top setscrew controls the top of the wheel, the left setscrew controls the left of the wheel and so forth.

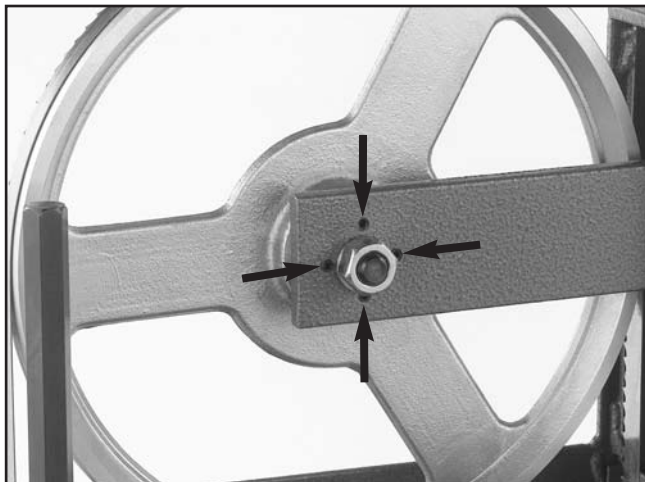

Figure 36. Blade tracking controls.

3. Adjust the tracking setscrews so that the blade remains in the center of the wheel when you spin the wheel by hand. After the blade appears to be tracking correctly, spin the wheel at least three full times to ensure that the blade remains centered, and then replace the upper wheel cover, turn on the machine and test the blade tracking. If there are problems, repeat **steps 1-3**.



Changing Blades

In the event that you need to change blades or remove the current blade for cleaning purposes, follow the instructions below:

1. **Disconnect the machine from the power source!**
2. Remove the force plate from the end of the table.
3. Slide the table off the rollers and remove it from the bandsaw unit.
4. Remove the stainless steel blade covers.
5. Move the blade guides away from the blade, so the blade can easily slide out and away from the blade guide assembly.
6. Remove the V-belt.
7. Release the tension from the blade by turning the blade tension bolt counterclockwise.
8. Remove the thumbscrew that holds the upper cover in place, then pull the upper cover off of the bandsaw unit.
9. Put on a pair of leather gloves to protect your hands from the sharp edges of the blade. Carefully remove the blade as shown in **Figure 37**.

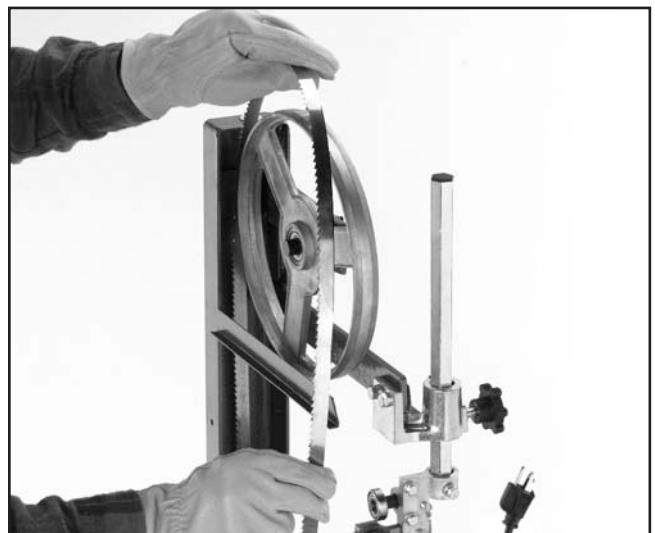

Figure 37. Removing the bandsaw blade.

10. Blade installation is the opposite of removal. Once the blade is installed, remember to tension it appropriately, set the blade guides, and replace the V-belt.

CAUTION

Make sure all components that were removed have been placed back in their original position, are adjusted correctly, and all guards are in place before you plug the bandsaw back into the power outlet. An injury may occur if this caution is ignored.



Support Bearing

The support bearing backs the blade during operation. As mentioned in the “Blade Guard” instructions, the blade guide assembly (with the support bearing) should be lowered to within an inch from the material you are cutting to be most efficient.

The support bearing shown in **Figure 38** should be approximately 0.016" away from the back of the blade. This is about four thicknesses of a dollar bill. To adjust the support bearing, loosen the support bearing shaft thumbscrew and slide the support bearing forward or backward as necessary.

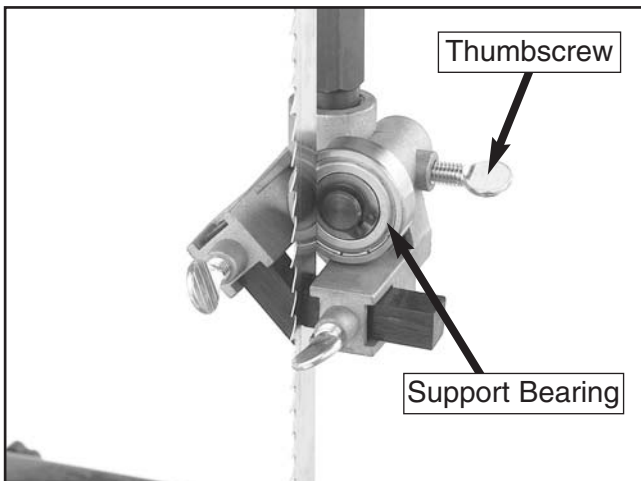

Figure 38. Support bearing.



Test Run

Once assembly is complete and adjustments are done to your satisfaction, you are ready to start the machine.

Press the START button. Make sure that your finger is poised on the STOP button just in case there is a problem. The bandsaw should run smoothly with little or no vibration or rubbing noises. Strange or unnatural noises should be investigated and corrected before operating the machine further.

Run the Model G0560 for a short time to ensure that the moving parts are working properly with no excessive vibration. If any problem develops, correct it before attempting to use the machine.

If you cannot locate the source of unusual noises, immediately contact our service department at (570) 546-9663.



NOTICE

The following section was designed to provide a basic understanding of the types of items that can be cut with the meat-cutting bandsaw. This manual is in no way a guide to cutting meat, dressing animals or safe meat handling techniques. **WE STRONGLY RECOMMEND** that you read books, magazines or take lessons that specifically deal with meat cutting and animal dressing applications.

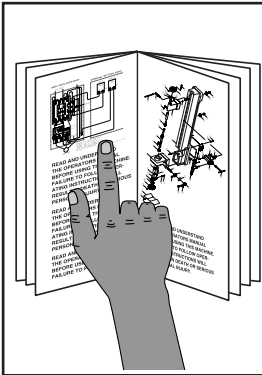

⚠️ WARNING

Read the entire manual before making any cuts with your bandsaw. Serious personal injury may result if safety or operational information is not understood or followed.

Cutting Meat

Your Model G0560 Meat-Cutting Bandsaw will cut through any fresh meat and almost all frozen meat.

To cut meat with your bandsaw:

1. Use the side fence to gauge the thickness of your desired cut. The front fence should brace the meat. Make sure that either of the fences or their rails will not be in line with the cut.
2. Turn the power *ON* and slowly guide the meat into the blade by sliding the table. With frozen meat, pay close attention to the rate at which you feed the meat into the moving blade. All cuts should be slow and smooth. If you hear the motor slow down or struggle with the cut, stop the cut.
3. Clear the slice you just cut and slide the meat toward the side fence. You can make successive cuts and the following slices will be the same thickness as the first.



⚠️ WARNING

This bandsaw can cut your fingers off or cause other bodily harm. Use a wooden push stick when cutting small pieces and always properly support any item you cut.

⚠️ WARNING

Bacteria from raw meat has been frequently linked to illness and even death! Describing proper meat handling techniques outside of cleaning the bandsaw is beyond the scope of this manual. If you are unclear about sanitary meat handling practices, contact your local Board of Health or the USDA to research the proper methods of meat handling.



Cutting Bone

Besides meat, this bandsaw can cut through bone too.

When cutting bone:

Feed the bone into the blade slowly. If you hear the motor slow down during cutting, stop cutting at once. DO NOT twist the blade during the cut. The blade may bind or break.

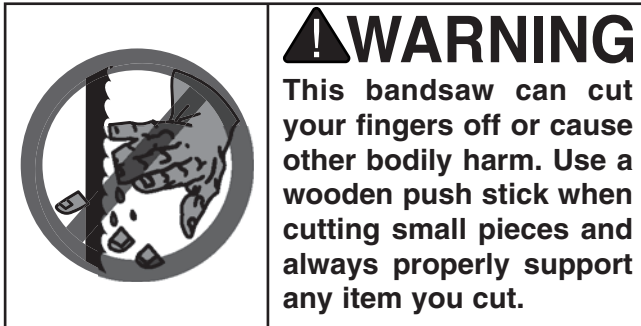

Grinding Meat

The meat grinder is great for grinding hamburger or sausage. The grinder automatically engages when it is mounted to the bandsaw unit.

To use the meat grinder:

1. Make sure that all the grinder components are cleaned and sanitized thoroughly before using them.
2. Lower the blade guard as low as it will go and lock it in place.
3. Prepare a place for the ground meat to exit the grinder.
4. Drop pieces of meat into the grinder, one at a time. Use the pusher to help the meat into the spinning auger, but do not overload the grinder.
5. Always clean and sanitize all parts of the grinder that have been exposed to meat or food particles.

DO NOT have the meat grinder installed on the bandsaw when not in use.

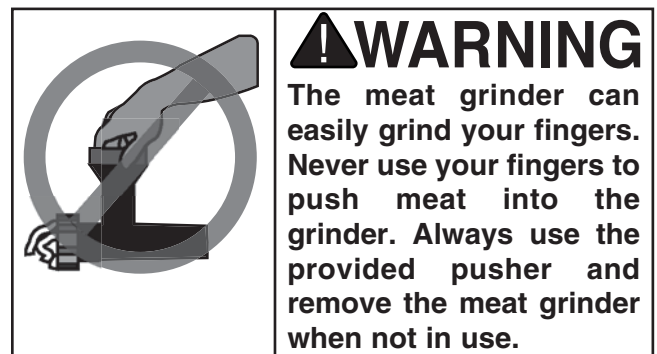

SECTION 7: CLEANING/SANITIZING



⚠️ WARNING

Always be as thorough as possible when cleaning and sanitizing your meat cutting bandsaw components. Any parts that have been exposed to raw meat or bone may harbor or develop bacteria that may cause illness or death if left uncleaned.

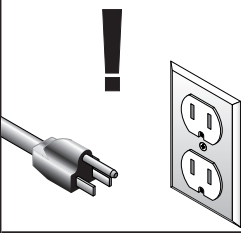

⚠️ WARNING

Cleaning the bandsaw while it is plugged in may cause severe electrical shock! Always disconnect the power before attempting any cleaning or maintenance operations, and after cleaning, never connect the bandsaw to a power source until it is dry. Failure to follow this warning may result in severe injury or even death.

⚠️ WARNING

When cleaning with sanitizers, always follow the recommendations on the manufacturer's label, and make sure that the product will do the job for which you intend. Never use a product that will cause exposed surfaces to render meat unsafe for human consumption. Failure to follow this warning may lead to sickness or death!

Cleaning the Saw

To clean your bandsaw after use:

1. Remove the table, the blade guards, the fences, and the meat grinder (**Figure 39**).
2. If used, disassemble the meat grinder (**Figure 40**).

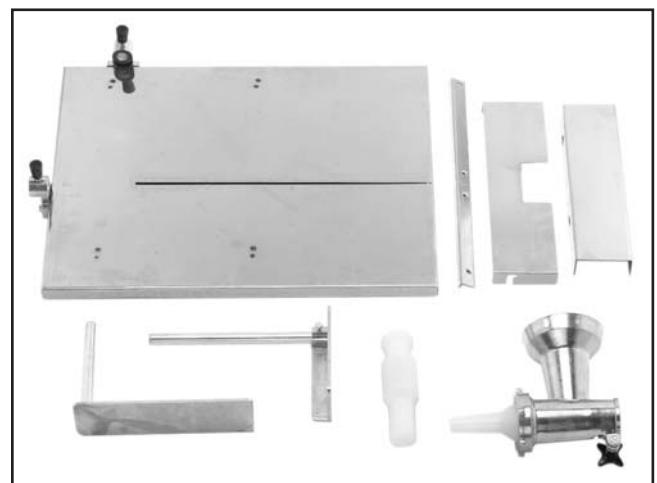

Figure 39. Pieces disassembled for cleaning.



Figure 40. Meat grinder components disassembled for cleaning.

3. Take off the upper wheel cover and open the cabinet door.

4. Remove the blade from the wheels of the bandsaw (as discussed in the “Changing Blades” instructions). Sanitize all removed pieces from the meat grinder and bandsaw, according to the following sanitation instructions. If you have access to a dishwasher, use it to sanitize the parts that will fit.
5. Clean the wheels and any other part of the bandsaw unit that may have been exposed to raw meat with a direct application sanitizer (read “Proper Sanitation” instructions).



Proper Sanitation

All surfaces and working parts that have been exposed to meat must be properly sanitized after each use.

Dishwashers are a good option because they sanitize with heat. For all pieces that will not fit in the dishwasher, or if a dishwasher is not available, **chemical sanitizers** like bleach or iodophor solution are good options. There are also other chemical sanitizers on the market that serve the same function. When using chemical sanitizers, make sure they are designed to do the job, and strictly follow the manufacturer’s recommendations for proper use.

Proper sanitation with chemical sanitizers requires a process before the actual sanitizer is applied.

The following is an effective method to prepare an item for sanitation:

1. Gather all the items that need to be cleaned. Remove the largest particles of foodstuffs into a proper garbage container. Rinse all items to remove as many of the leftover particles as possible. Set the items aside.
2. Prepare the sink. Wash and scrub all sink compartments with dish soap and hot water. Rinse these compartments thoroughly.

3. Fill a sink with soapy water, submerge the item and scrub the entire surface thoroughly.
4. Using hot water, rinse the newly cleaned item in the empty compartment, until all visible suds have been removed. Repeat this process for all of the items that need to be sanitized. If the soapy water starts to get hazy, drain and rinse the sink, then fill with more soapy water.

The items are now ready to be sanitized. Some sanitizers require direct applications, while others are designed to be diluted in water and used to soak the item for a specified period of time. The best method for choosing a chemical sanitizer is to do the research and determine which product is best for your particular situation.

One simple sanitizer that can be used for many applications is regular bleach. To use bleach as a sanitizer, wash, scrub, and rinse your sink. For all non-porous surfaces (includes all parts of this bandsaw), fill the sink with one tablespoon of bleach per gallon of cool water. Do not use bleach that contains odor masking agents or surfactants. These have not been proven effective for this type of sanitation. Submerge each item for two minutes. For large items, submerge each side for the specified amount of time until you have covered the entire area. Allow to air dry. **Do not rinse these items after sanitation!**

If your raw meat comes into contact with non-porous surfaces (wood), clean as described above and soak these surfaces for two minutes in a solution of 3 tablespoons of bleach to one gallon of cool water. **Rinse these items well!**



SECTION 8: MAINTENANCE

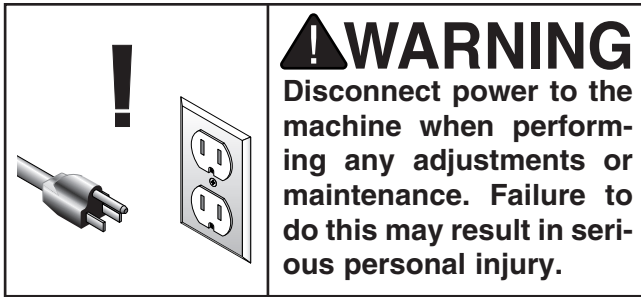

General

Regular periodic maintenance on your Model G0560 Meat-Cutting Bandsaw ensures its optimum performance. Make a habit of inspecting your bandsaw each time you use it.

Check for the following conditions and repair or replace when necessary.

1. Loose mounting bolts.
2. Worn switch.
3. Worn or damaged cords and plugs.
4. Damaged V-belt.
5. Any other condition that could hamper the safe operation of this machine.



Table & Blade

Maintain your table and blade with a thin film of food grade lubricant that will not support bacteria growth and will not become rancid. These qualities are important because some food grade oils will become rancid over time and may cause illnesses. Make sure that the product you use is specifically designed for protecting food processing machinery. Always follow the manufacturer's recommendations when using their products.



Lubrication

The wheel bearings are shielded and lubricated for life; thus, they require no maintenance throughout their lifespan. Occasionally lubricate the tracking and height adjustment controls with the same food grade lubricant that you use on the table.

DO NOT lubricate the meat grinder. The meat processed in the meat grinder naturally lubricates the grinder.



V-Belt

Avoid getting grease or oil on the V-belt or pulleys. Check the V-belt, as part of a monthly inspection for proper tension and belt condition. Cracking and glazing could result in belt failure. Replace the belt if such conditions appear.



SECTION 7: REFERENCE INFO

The following pages contain the machine data sheets, wiring diagram, parts diagrams, parts lists, and the Warranty/Return information for the Model G0560.

If you need parts or help in assembling your machine, or if you need operational information, call the Grizzly Service Department. Trained service technicians will be glad to help you.

If you have any comments regarding this manual, please write to Grizzly at the address below:

Grizzly Industrial, Inc.
c/o Technical Documentation
P.O. Box 2069
Bellingham, WA 98227-2069

We recommend you keep a copy of our current catalog for complete information regarding Grizzly's warranty and return policy. If you need additional technical information relating to this machine, or if you need general assistance or replacement parts, please contact the Service Department at the location listed below.

Grizzly Industrial, Inc.
1203 Lycoming Mall Circle
Muncy, PA 17756
Phone: (570) 546-9663
Fax: (800) 438-5901
E-Mail: techsupport@grizzly.com
Web Site: <http://www.grizzly.com>.





MACHINE DATA SHEET

Customer Service #: (570) 546-9663 • To Order Call: (800) 523-4777 • Fax #: (800) 438-5901

GRIZZLY MODEL G0560 MEAT-CUTTING BANDSAW

Design Type Floor Model

Overall Dimensions:

Table22½" L x 16¾" W
 Height56"
 Height From Floor to Table35⅝"
 Width of Unit19"
 Shipping Weight.....138 lbs.
 Weight in Place127 lbs.
 Box Size36¼" L x 19½" W x 16½" H
 Footprint16" x 18"

Cutting Capacity:

Height9¼"
 Throat9¾"
 Blade Length77½"
 Blade Speed.....990 FPM
 Range of Table Slide Movement (with fence)8¼"
 Max Width of Cut of Table Slide Movement (with fence)8½"
 Fence Adjustment8"
 Sausage Grinder Speed380 RPM

Construction:

TableStainless Steel
 WheelsAluminum - Ball Bearing
 FenceDie Cast Aluminum
 Wheel Covers.....Pre-Formed Steel
 Guides.....Upper Bakelite guide, Rear Ball Bearing Support

Motor:

TypeTEFC Capacitor Start Induction
 Horsepower¾ HP
 Phase / CycleSingle Phase / 60 Hz
 Voltage110V / 220V
 Amps.....12A / 6A
 RPM.....1725 RPM
 BearingsShielded & Permanently Lubricated Ball
 SwitchToggle Safety Switch

Features:

.....Includes ⅝" Blade, Meat Grinder, and Sausage Stuffer
Sliding Table (Ball Bearing Support)

Specifications, while deemed accurate, are not guaranteed.

11-21-03

G0560 Wiring Diagram



⚠ DANGER
 Disconnect power from machine before performing any electrical service. Failure to do this will result in a shock hazard leading to injury or death. The motor starting capacitor can still retain a charge even with the power disconnected. Turn the switch to the Forward position to discharge the capacitor. Failure to do so will lead to a severe shock hazard.

NOTE: THE WIRES FROM THE POWER SUPPLY, BESIDES THE GREEN GROUND WIRE, ARE INTERCHANGABLE, THEREFORE COLORS ARE NOT SPECIFIED.

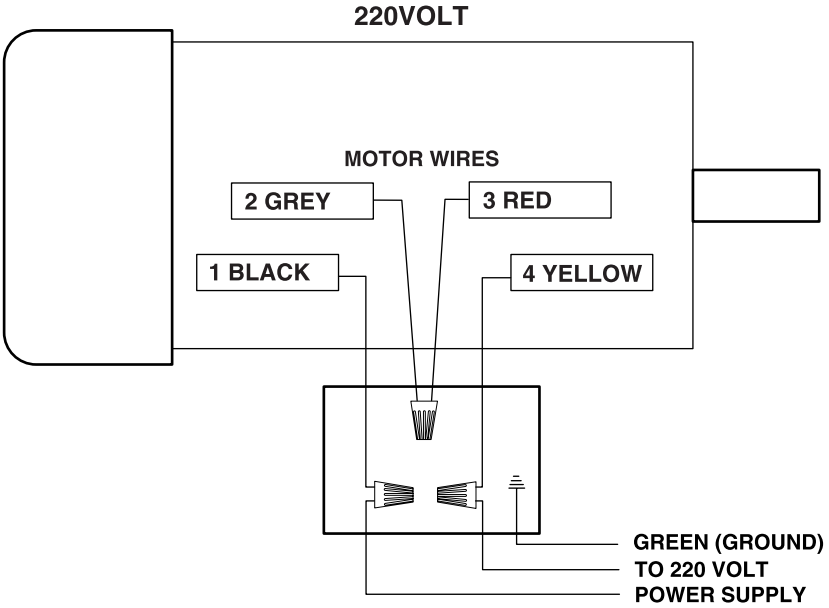
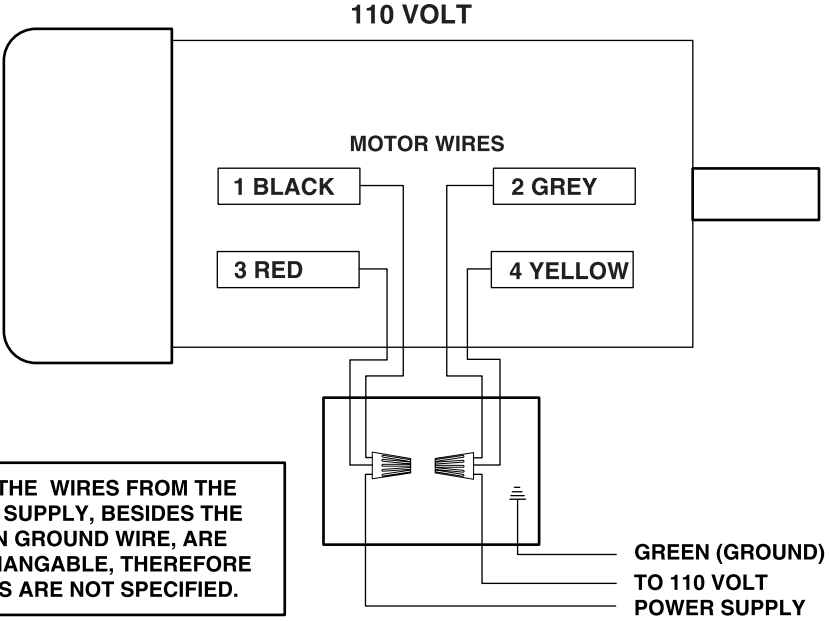

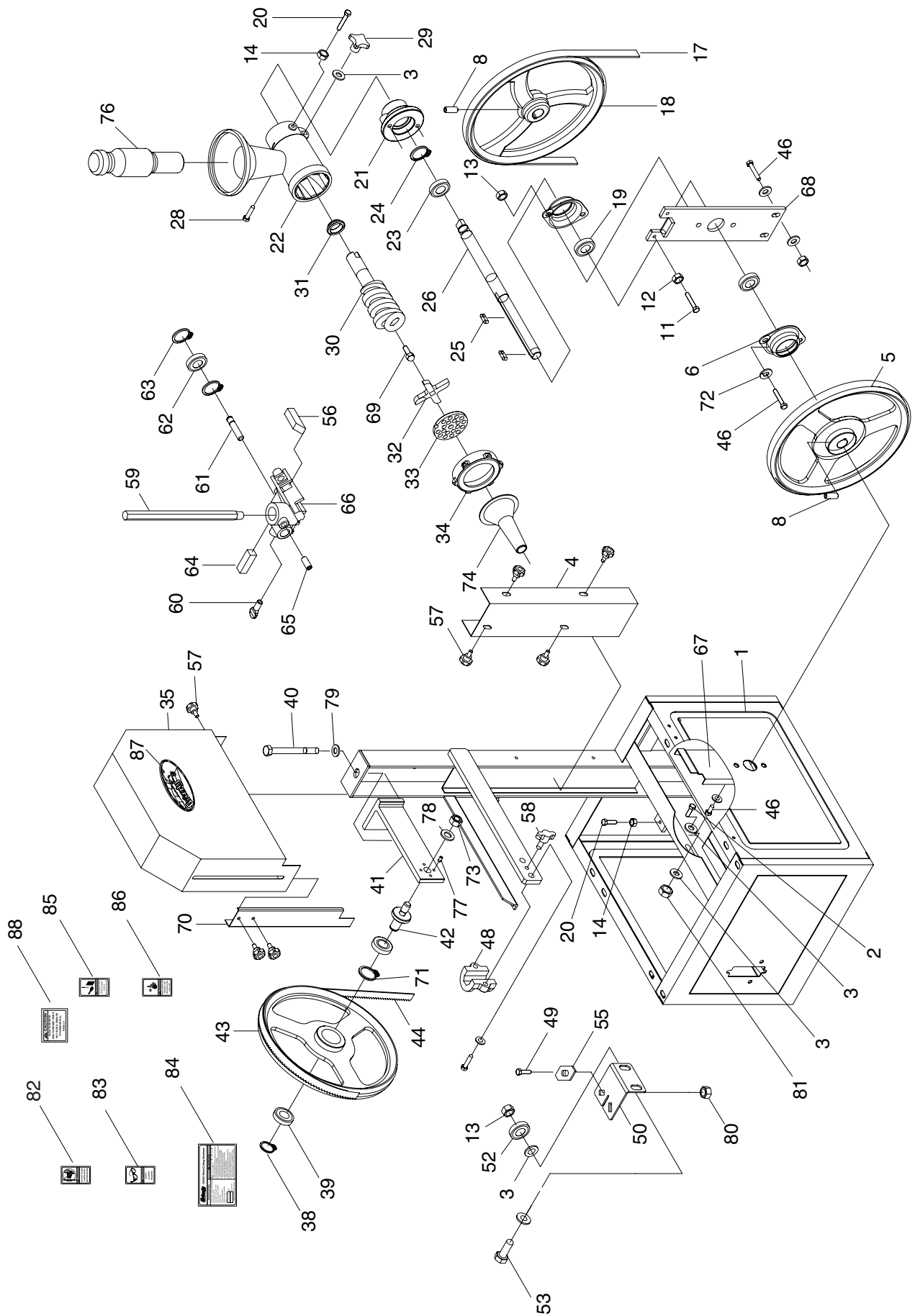

G0560 Main Saw Assembly

REF	PART #	DESCRIPTION
1	P0560001	Bandsaw Base
2	PN03M	Hex Nut M8-1.25
3	PW01M	Flat Washer 8MM
4	P0560004	Blade Cover
5	P0560005	Lower Blade Wheel
6	P0560006	Set Bearing
8	PSS01M	Set Screw M6-1 X 10
11	PB10M	Hex Bolt M6-1 X 25
12	PN01M	Hex Nut M6-1
13	PN03M	Hex Nut M8-1.25
14	PN01M	Hex Nut M6-1
17	PVA53	V-Belt A-53 4I530
18	P0560018	Pulley
19	P6204	Ball Bearing 6204ZZ
20	PB08M	Hex Bolt M6-1 X 20
21	P0560021	Bracket
22	P0560022	Grinding Hopper
23	P6203	Ball Bearing 6203ZZ
24	PR18M	Ext Retaining Ring 17MM
25	PK23M	Key 5 X 5 X 25
26	P0560026	Shaft
28	PCB18M	Carriage Bolt M8-1.25 X 45
29	P0560029	Square Knob M8-1.25
30	P0560030	Shaft, Thrust
31	P0560031	Bushing
32	P0560032	Reamer
33	P0560033	Filter Cover #4
34	P0560034	Lock Cover
35	P0560035	Upper Cover
38	PR05M	Ext Retaining Ring 15MM
39	P6202	Ball Bearing 6202ZZ
40	P0560040	Hex Bolt M10-1.5 X 115
41	P0560041	Bracket
42	P0560042	Shaft Bracket
43	P0560043	Upper Blade Wheel
44	P0560044	Blade
46	PB09M	Hex Bolt M8-1.25 X 20
48	PN01M	Hex Nut M6-1

REF	PART #	DESCRIPTION
49	PFB01M	Flange Bolt M6-1 X 12
50	P0560050	Lower Guide Seat
51	PW03M	Flat Washer 6mm
52	P608ZZ	Ball Bearing 608ZZ
53	PB07M	Hex Bolt M8-1.25 X 25
55	P0560055	Clamping Luge
56	P0560056	Blade Guide Block
57	P0560057	Star Knob M6-1 X 12
58	P0560058	Star Knob M8-1.25 X 20
59	P0560059	Screw Bar
60	PTS001M	Thumb Screw M6-1 X 16
61	P0560061	Blade Guide Bar
62	P6200ZZ	Ball Bearing 6200ZZ
63	PR01M	Ext Retaining Ring 10MM
64	P0560064	Blade Guide Block
65	PSS01M	Set Screw M6-1 X 10
66	P0560066	Blade Guide Holder
67	P0560067	Connector Fixed Plate
68	P0560068	Lower Wheel Fixed Plat
69	P0560069	Rod Set Screw
70	P0560070	Blade Guard
71	PR21M	Int Retaining Ring 35MM
72	PLW04M	Lock Washer 8MM
73	PN09M	Hex Nut M12-1.75
74	P0560074	Sausage Stuffer
76	P0560076	Pusher
77	PSS05M	Set Screw M5-.8 X 10
78	PLW05M	Lock Washer 12MM
79	PW04M	Flat Washer 10MM
80	PCB12M	Carriage Bolt M6-1 x 12
81	PCB06M	Carriage Bolt M8-1.25 X 16
82	P0560082	Hand Near Blade Label
83	P0560083	Safety Glasses Label
84	P0560084	Machine ID Label
85	P0560085	Unplug 110V Label
86	P0560086	Wash Hands Label
87	G9987	Grizzly Logo Plate
88	P0560086	Meat Grinder Label

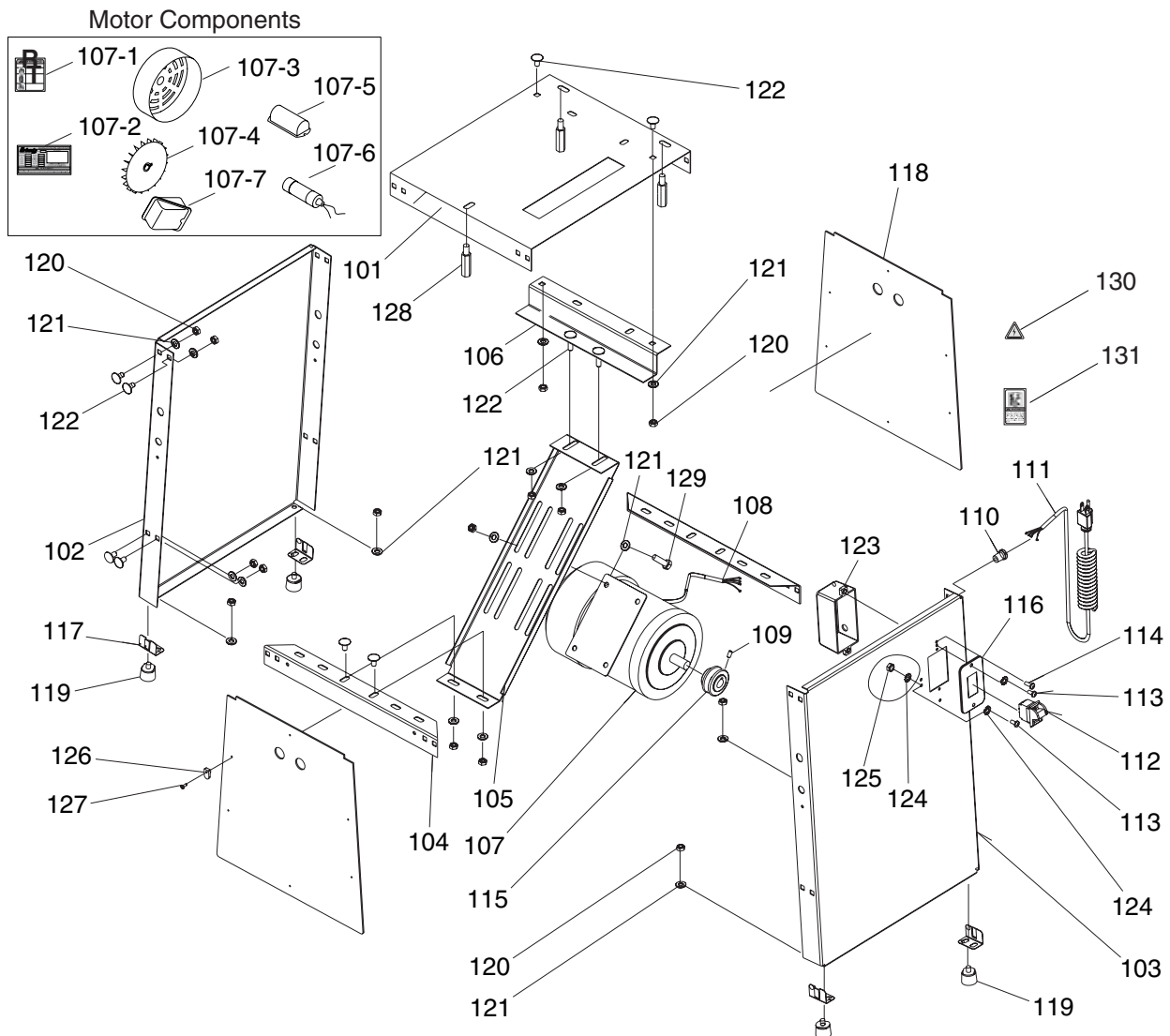

G0560 Stand & Motor Assembly

REF PART #	DESCRIPTION
101	P0560101 Face Plate
102	P0560102 Rear Plate
103	P0560103 Front Plate
104	P0560104 Lower Bracket
105	P0560105 Motor Plate
106	P0560106 Upper Bracket
107	P0560107 Motor
107-1	PLABEL-38 Gen Motor Label
107-2	P0560107-2 G0560 Motor Data Label
107-3	P0560107-3 Motor Fan Cover
107-4	P0560107-4 Motor Fan
107-5	P0560107-5 Capacitor Cover
107-6	P0560107-6 Start Capacitor 200M 125V
107-7	P0560107-7 Motor Wiring Box
108	P0560108 Motor Cord
109	P0560109 Set Bolt M6-1 X 6
110	P0560110 Cord Bushing
111	P0560111 Power Cord
112	P0560112 Switch

REF PART #	DESCRIPTION
113	PS01 Phlp Hd Scr 10-24 X 1/2
114	PS22 Phlp Hd Scr 10-24 X 5/8
115	P0560115 Motor Pulley
116	P0560116 Switch Plate
117	P0560117 L Type Set Plate
118	P0560118 Side Cover
119	P0560119 Rubber Pad
120	PN03M Hex Nut M8-1.25
121	PW01M Flat Washer 8MM
122	PCB06M Carriage Bolt M8-1.25 X 16
123	P0560123 Switch Box
124	PTLW02M Ext Tooth Washer 5MM
125	PN07 Hex Nut #10-24
126	P0560126 Clamp Door
127	PHTEK18M Tap Screw M3.5 X 10
128	P0560128 Set Bolt
129	PB09M Hex Bolt M8-1.25 X 20
130	PLABEL-14 Electricity Label
131	P0560131 Read Manual Label

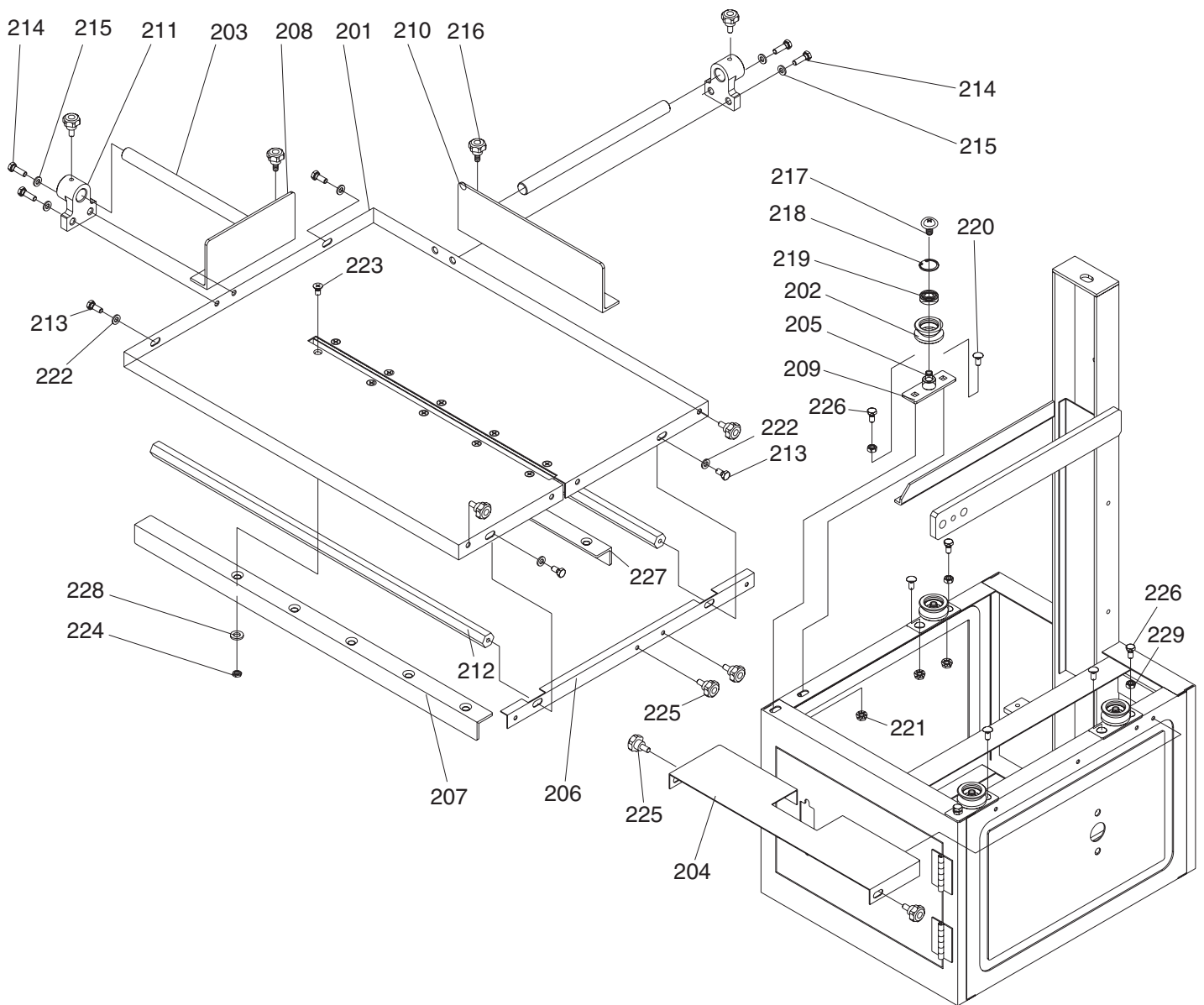

G0560 Sliding Table Assembly

REF PART #	DESCRIPTION
201	P0560201 Table (sliding)
202	P0560202 Rollers
203	P0560203 Stand Rod
204	P0560204 Guard Cover
205	P0560205 Roller Shaft
206	P0560206 Fixed Plate
207	P0560207 Right-support
208	P0560208 Pusher
209	P0560209 Roller Fixed Plate
210	P0560210 Left Fence
211	P0560211 Supporter
212	P0560212 Guide Rail
213	PB02M Hex Bolt M6-1 X 12
214	PB08M Hex Bolt M6-1 X 20
215	PW03M Flat Washer 6MM

REF PART #	DESCRIPTION
216	PS14M Phlp Hd Scr M6-1 X 12
217	PFB08M Flange Bolt M5-.8 X 10
218	PR57M Int Retaining Ring 22mm
219	P608ZZ Ball Bearing 608ZZ
220	PCB12M Carriage Bolt M6-1 X 12
221	PFN02M Flange Nut M6-1
222	PW03M Flat Washer 6MM
223	PFH07M Flat Hd Screw M5-.8 X 10
224	PN06M Hex Nut M5-.8
225	P0560225 Knob Bolt M6-1 X 12
226	PB83M Hex Bolt M6-1 X 16
227	P0560227 Left-support
228	PW02M Flat Washer 5MM
229	PN01M Hex Nut M6-1

WARRANTY AND RETURNS

Grizzly Industrial, Inc. warrants every product it sells for a period of **1 year** to the original purchaser from the date of purchase. This warranty does not apply to defects due directly or indirectly to misuse, abuse, negligence, accidents, repairs or alterations or lack of maintenance. This is Grizzly's sole written warranty and any and all warranties that may be implied by law, including any merchantability or fitness, for any particular purpose, are hereby limited to the duration of this written warranty. We do not warrant or represent that the merchandise complies with the provisions of any law or acts unless the manufacturer so warrants. In no event shall Grizzly's liability under this warranty exceed the purchase price paid for the product and any legal actions brought against Grizzly shall be tried in the State of Washington, County of Whatcom.

We shall in no event be liable for death, injuries to persons or property or for incidental, contingent, special, or consequential damages arising from the use of our products.

To take advantage of this warranty, contact us by mail or phone and give us all the details. We will then issue you a "Return Number," which must be clearly posted on the outside as well as the inside of the carton. We will not accept any item back without this number. Proof of purchase must accompany the merchandise.

The manufacturers reserve the right to change specifications at any time because they constantly strive to achieve better quality equipment. We make every effort to ensure that our products meet high quality and durability standards and we hope you never need to use this warranty.

Please feel free to write or call us if you have any questions about the machine or the manual.

Thank you again for your business and continued support. We hope to serve you again soon.

WARRANTY CARD

Name _____
 Street _____
 City _____ State _____ Zip _____
 Phone Number _____ E-Mail _____ FAX _____
MODEL: _____ **Serial #** _____ **Order** _____

The following information is given on a voluntary basis. It will be used for marketing purposes to help us develop better products and services. Of course, all information is strictly confidential.

CUT ALONG DOTTED LINE

1. How did you learn about us?

<input type="checkbox"/> Advertisement <input type="checkbox"/> Catalog <input type="checkbox"/> World Wide Web <input type="checkbox"/> Other _____	<input type="checkbox"/> Friend <input type="checkbox"/> Card Deck
---	---

2. Which of the following magazines do you subscribe to.

<input type="checkbox"/> American Woodworker <input type="checkbox"/> Cabinetmaker <input type="checkbox"/> Family Handyman <input type="checkbox"/> Fine Homebuilding <input type="checkbox"/> Fine Woodworking <input type="checkbox"/> Home Handyman <input type="checkbox"/> Journal of Light Construction <input type="checkbox"/> Old House Journal <input type="checkbox"/> Popular Mechanics <input type="checkbox"/> Popular Science <input type="checkbox"/> Popular Woodworking <input type="checkbox"/> Other _____	<input type="checkbox"/> Practical Homeowner <input type="checkbox"/> Shop Notes <input type="checkbox"/> Today's Homeowner <input type="checkbox"/> WOOD <input type="checkbox"/> Wooden Boat <input type="checkbox"/> Woodshop News <input type="checkbox"/> Woodsmith <input type="checkbox"/> Woodwork <input type="checkbox"/> Woodworker <input type="checkbox"/> Woodworker's Journal <input type="checkbox"/> Workbench
--	---

3. Which of the following woodworking/remodeling shows do you watch?

<input type="checkbox"/> Backyard America <input type="checkbox"/> Home Time <input type="checkbox"/> The American Woodworker <input type="checkbox"/> Other _____	<input type="checkbox"/> The New Yankee Workshop <input type="checkbox"/> This Old House <input type="checkbox"/> Woodwright's Shop
---	---

4. What is your annual household income?

<input type="checkbox"/> \$20,000-\$29,999 <input type="checkbox"/> \$30,000-\$39,999 <input type="checkbox"/> \$40,000-\$49,999 <input type="checkbox"/> \$50,000-\$59,999	<input type="checkbox"/> \$60,000-\$69,999 <input type="checkbox"/> \$70,000-\$79,999 <input type="checkbox"/> \$80,000-\$89,999 <input type="checkbox"/> \$90,000 +
--	---

5. What is your age group?

<input type="checkbox"/> 20-29 <input type="checkbox"/> 30-39 <input type="checkbox"/> 40-49	<input type="checkbox"/> 50-59 <input type="checkbox"/> 60-69 <input type="checkbox"/> 70 +
--	---

6. How long have you been a woodworker?

<input type="checkbox"/> 0 - 2 Years <input type="checkbox"/> 2 - 8 Years	<input type="checkbox"/> 8 - 20 Years <input type="checkbox"/> 20+ Years
--	---

7. How would you rank your woodworking skills?

<input type="checkbox"/> Simple <input type="checkbox"/> Intermediate	<input type="checkbox"/> Advanced <input type="checkbox"/> Master Craftsman
--	--

8. What stationary woodworking tools do you own? Check all that apply.

<input type="checkbox"/> Air Compressor <input type="checkbox"/> Band Saw <input type="checkbox"/> Drill Press <input type="checkbox"/> Drum Sander <input type="checkbox"/> Dust Collector <input type="checkbox"/> Horizontal Boring Machine <input type="checkbox"/> Jointer <input type="checkbox"/> Lathe <input type="checkbox"/> Mortiser	<input type="checkbox"/> Panel Saw <input type="checkbox"/> Planer <input type="checkbox"/> Power Feeder <input type="checkbox"/> Radial Arm Saw <input type="checkbox"/> Shaper <input type="checkbox"/> Spindle Sander <input type="checkbox"/> Table Saw <input type="checkbox"/> Vacuum Veneer Press <input type="checkbox"/> Wide Belt Sander
--	--

9. How many of your woodworking machines are Grizzly? _____
 Other _____

10. Which benchtop tools do you own? Check all that apply.

<input type="checkbox"/> 1" x 42" Belt Sander <input type="checkbox"/> 5" - 8" Drill Press <input type="checkbox"/> 8" Table Saw <input type="checkbox"/> 8" - 10" Bandsaw <input type="checkbox"/> Disc/Belt Sander <input type="checkbox"/> Mini Jointer <input type="checkbox"/> Other _____	<input type="checkbox"/> 6" - 8" Grinder <input type="checkbox"/> Mini Lathe <input type="checkbox"/> 10" - 12" Thickness Planer <input type="checkbox"/> Scroll Saw <input type="checkbox"/> Spindle/Belt Sander
---	---

11. How many of the machines checked above are Grizzly? _____

12. Which portable/hand held power tools do you own? Check all that apply.

13. What machines/supplies would you like Grizzly Industrial to carry?

14. What new accessories would you like Grizzly Industrial to carry?

<input type="checkbox"/> Builders Hardware <input type="checkbox"/> Fasteners <input type="checkbox"/> Other _____	<input type="checkbox"/> Hand Tools <input type="checkbox"/> Wood Components
--	---

15. What other companies do you purchase your tools and supplies from?

16. Do you think your purchase represents good value?
 Yes No

17. Would you recommend Grizzly Industrial to a friend?
 Yes No

18. Would you allow us to use your name as a reference for Grizzly customers in your area? **Note: We never use names more than three times.**
 Yes No

19. Comments: _____

FOLD ALONG DOTTED LINE



Place
Stamp
Here



GRIZZLY INDUSTRIAL, INC.
P.O. BOX 2069
BELLINGHAM, WA 98227-2069



FOLD ALONG DOTTED LINE

Send a Grizzly Catalog to a friend:

Name _____
Street _____
City _____ State _____ Zip _____

TAPE ALONG EDGES--PLEASE DO NOT STAPLE

grizzly.com

TOOL WEBSITE

Buy Direct and Save with Grizzly® – Trusted, Proven and a Great Value!

*Visit Our Website Today And Discover Why
Grizzly® Is The Industry Leader!*

- SECURE ORDERING
- ORDERS SHIPPED WITHIN 24 HOURS
- E-MAIL RESPONSE WITHIN ONE HOUR

-OR-

Call Today For A **FREE**
Full Color Catalog

1-800-523-4777

